

Montpellier

THE PERFECT BALANCE OF FUNCTION AND STYLE

LAUNDRY - DISHWASHING - COOKING - COOLING

Installation and Operating Instructions



Built In Gas Hob - 75cm

GH75BG/GH71X - Black Glass/Stainless Steel

Please read these instructions carefully before attempting to install or use this appliance.
We recommend that you keep these instructions in a safe place for future reference.

Welcome

Thank you for choosing this Montpellier Gas Hob.

Our Gas Hobs have been designed to provide you with the best combination of style, reliability and performance to give you years of trouble-free use.

You may be familiar with a similar product, but please take time to read these instructions carefully before installing or using your Hob to ensure you get the most from your purchase.

We recommend that you keep this manual in a safe place for future reference.



Your Gas Hob is covered by a comprehensive two year Parts & Labour Guarantee. In the unlikely event that you experience a problem with your Hob, you can rest assured that you are fully protected against the cost of repairs for the first 24 months. Please note that any claim must be accompanied by the model reference number, serial number and proof of purchase.

To activate your guarantee, you will need your product serial number. This can be found on the rear of the machine.

There are two ways to register your Guarantee:

- **Online:** Visit the Support page on our website and complete the online Product Registration form. www.montpellier-appliances.com
- **By Post:** Simply detach and fill in the form provided, attach a stamp and send it in the post. Don't forget to include your e-mail address so that we can send confirmation through to you.



Note: We are unable to take registrations over the phone.

Description Of The Appliance

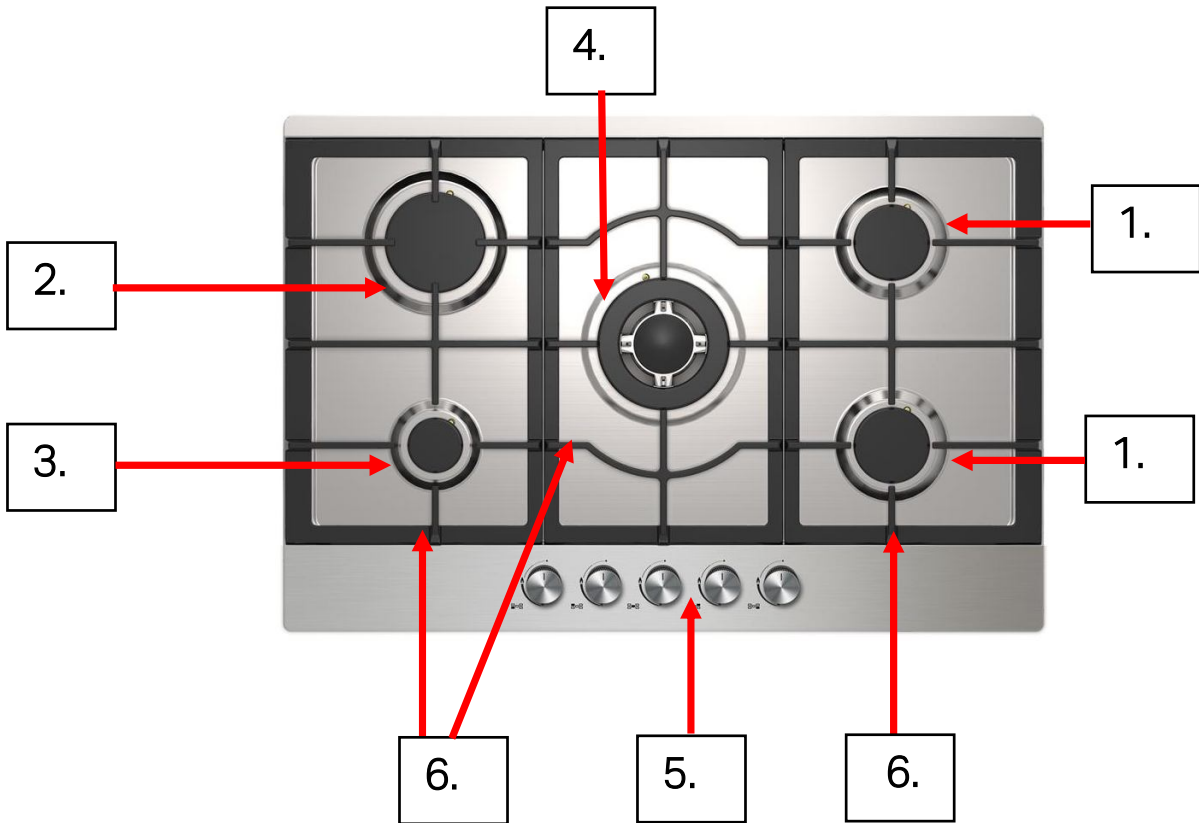

(Stainless Steel model shown for indicative purposes)

1. 1.75kW Burners
2. 3.0kW Burner
3. 1.0kW Burner
4. 3.3kW Burner
5. Burner Control Knobs
6. Pan Supports

CONTENTS:

Section 1. Installation

Section 2. Safety Advice

Section 3. Operating the Appliance

Section 4. Maintenance

Section 1 - Installation

- Remove all packaging, protective film and securing tape from the appliance.
- Position the appliance in a dry atmosphere.
- The following dimensions are provided as a guide for installation – your **GasSafe** installer will carry out the installation in accordance with the current regulations.
- Your **GasSafe** installer will connect the appliance in accordance with the current regulations.

To install this appliance, please proceed as follows:

1.1. Work-Surface Cut-Out & Positioning

- Cut out the work-top, ensuring that the actual sizes used are as per the diagram below (560mm x 490mm).
- For installation and use, a minimum of 5cm must be maintained around the cut-out.
- The work surface must have a thickness of at least 30mm.
- The work surface must be heat resistant.
- The rear edge of the hob must be at least 60mm from the rear wall.
- You must maintain a clearance of at least 700mm between the top of the hob and any surface directly above it.
- Note the clearances required between the hob/work surface and any adjacent wall cupboard (400mm).
- You must ensure that there is a minimum gap of 25mm between the bottom surface of the hob and anything positioned directly below it.

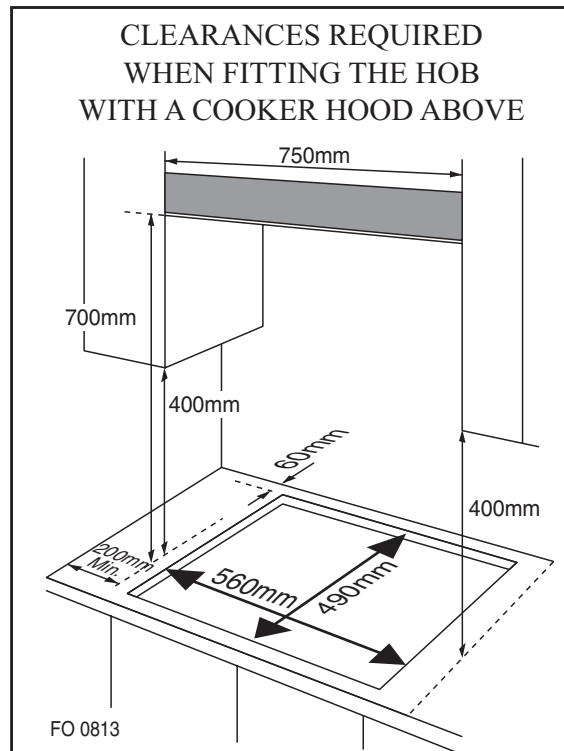
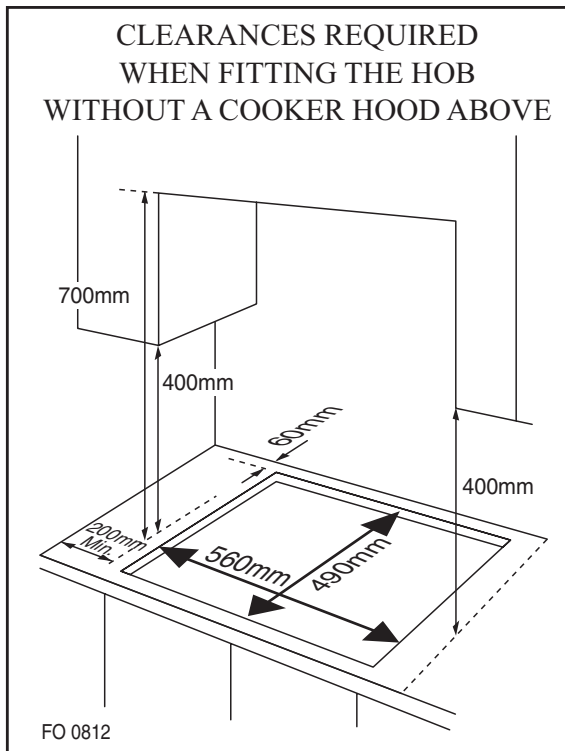

1.2. Sealing/Fixing the Hob Into Position

- Fix the sealing tape (A) to the underneath rim of the hob as follows:

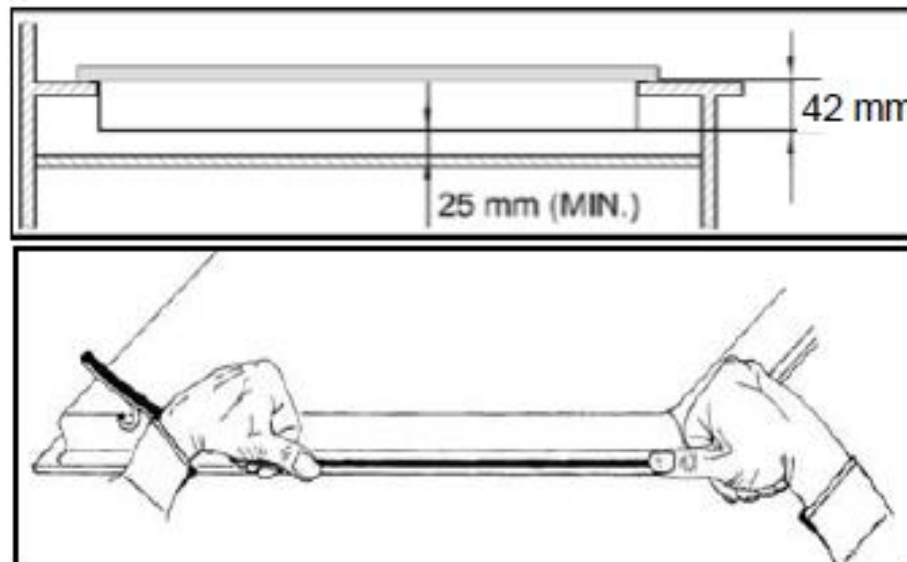

- Loosely fix the brackets (B) to the underside of the hob using screws (C) then carefully turn the hob upright and lower into the work-surface cut-out.

- Once the hob is in position, ensure the fixing brackets are positioned overlapping the under-side of the work-surface and then tighten the bracket screws to secure the hob into position.

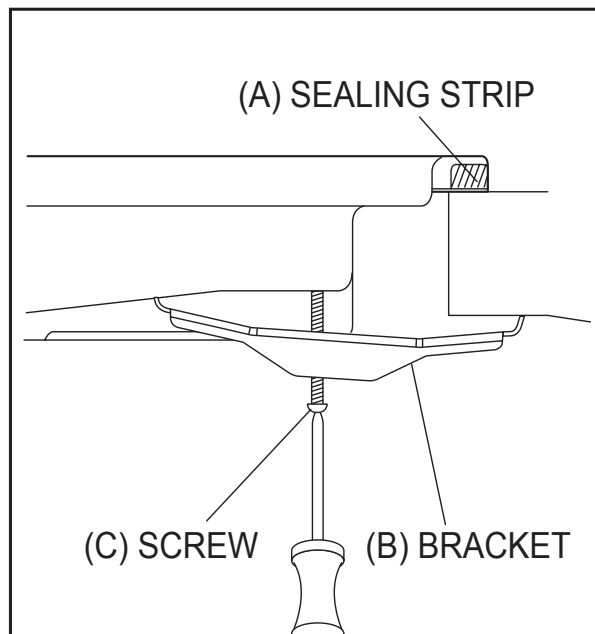

1.3. Electrical Connection

These appliances require an electrical connection for the spark ignition only. Connect the wires to a 3 Amp Plug, (protected by a 5amp fuse) and plug into a standard, switchable 13 Amp socket behind the housing unit. Please note that a switchable spur should be accessible above the work surface in order that the power can be turned off.

Green/Yellow = Earth
Blue = Neutral
Brown = Live

1.4. Gas Connection

This appliance must be installed by a 'Gas Safe' engineer. Your approved 'Gas Safe' engineer will ensure that your appliance is connected in accordance with the current regulations.

Section 2. Safety Advice

- **This appliance must be installed by a 'Gas Safe' engineer.**
- Please read this booklet thoroughly before installing and switching on the appliance. The manufacturer accepts no responsibility for incorrect installation and usage.
- This appliance is guaranteed for Domestic Use Only. This appliance shall not be used by children aged from 8 years and above and persons with reduced physical, sensory or mental capabilities, or lack of experience and knowledge, unless they have been given supervision or instruction on how to use the appliance in a safe way and understand the hazards involved. Children shall not play with the appliance. Cleaning and user maintenance shall not be made by children without supervision.
- This appliance must only be used for cooking/heating foods and liquids. Do not use it for any other purpose.
- **It is important that you use only metal pans specifically designed and/or approved for use on Gas Hobs. Never allow melamine or plastic containers to come in contact with the burners.**
- If using an adaptor, this must be used in accordance with the manufacturers instructions and ensure that the electrical circuit is not overloaded as this could cause overheating.
- Do not twist or bend the cables, and keep them away from hot surfaces. Following installation make sure that the power cable is not trapped underneath the appliance.
- Keep the appliance burners and surfaces clean. Failure to do this could lead to the appliance malfunctioning.
- The burners and surface of this appliance will get extremely hot during use and will remain hot after it has been turned off. Do not touch or clean the burners, pan supports or surfaces until it has completely cooled down.
- If the power supply cord is damaged, it must be replaced by the manufacturer, it's service agent or similarly qualified persons in order to avoid a hazard.

Section 3. Operating the Appliance

3.1. Igniting & Operating the Gas Burners



- Push in and turn the required burner control knob anti-clockwise to the maximum heat setting (Large flame).
- You will hear an audible click from the spark ignition.
- Continue to maintain pressure on the control knob for a few seconds after the burner has ignited and the flame is stable.
- If you fail to maintain pressure on the control knob, the burner will either not light or the flame will go out.
- Once the flame is stable you can turn the burner down to a lower heat setting, if required.
- When you have finished using the burner, turn the burner control knob back to the 'off' position and beware that the burner and pan support will remain hot for a period of time.

3.2. Hot Burners and Pan Supports

Please note that the gas burners, burner caps and pan supports will remain very hot for some time after the burner has been switched off. You must take care until the parts have cooled down completely.

Never, clean the hob surface, burners and/or pan supports until they have cooled down completely.

Section 4. Maintenance

Before any maintenance or cleaning work is carried out, DISCONNECT the appliance from the ELECTRICITY supply and ensure that the appliance is completely cool.

4.1. Cleaning the Hob Surface

Clean spillages from the hob surface as soon as possible after use. Always ensure that the surface has cooled down before cleaning.

Use a soft cloth or kitchen paper to clean the surface. If the spillage has dried on the surface you may need to use a specialist vitro-ceramic glass cleaner or stainless steel cleaner, available from all good supermarkets.

Do not use other abrasive cleaners and/or wire wool etc as this may scratch the surface of the hob.

4.2. Cleaning the Burners

Clean the burner parts with warm soapy water and a cream cleaner if required.

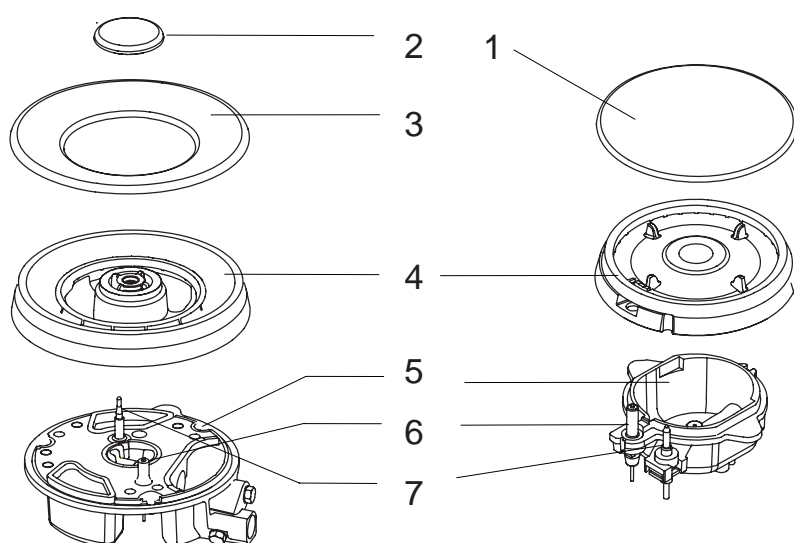

After removing and cleaning the burner cap(s) and burner skirt, re-assemble as follows:

Place the burner skirt (4) onto the burner base (5) ensuring that it sits correctly over the spark electrode (6) and the flame failure electrode (7).

Now place the burner cap (1, 2 & 3) onto the burner skirt (4) ensuring that they are sitting central – the central pins will sit into recesses.

4.3. What to do if something goes wrong

The spark ignition will not operate:



- Check there is not a power cut
- Check there is power to the electric socket/ appliance

The gas burners will not operate:

- Have you pushed in the control knob and maintained pressure for at least 10 seconds after the burner has lit?

4.3. Specifications

Please refer to the Rating Label on the appliance – example shown below (MON-GH75BG).

		Montpellier		  0063-18 Pin 0063CP7539			
Product Name	Gas hob						
Model Number	MON-GH75BG						
Cat	I3+(28-30/37)	I3B/P(30)	I2L	I2H/I2E/I2E+	II2H3+	II2H3B/P(30)	II2E+3+
Country code	BE, CH, CY, CZ, ES, FR, GB, GR, IE, IT, LT, LU, LV, PT, SK, SI.	BE, CY, DK, EE, FR, GB, HU, IT, LT, NL, NO, SE, SI, SK, RO, HR, TR, BG, IS, LU, MT, FI	NL	AT,CH,CZ,DK,ES,FI,GB,GR,IE,IS,IT,PT,SE,SI,SK,DE,LU,GE,FR	CH, CZ,ES,GB,GR,IE, IT,PT,SI	CH,CZ,DK,FI,GR,SE,SI,SK	BE, FR
Categories	G30 Butane at 28-30mbar and G31 Propane at 37mbar	G30 Butane and G31 Propane at 30mbar	G25 Methane 25mbar	G20 Methane 20mbar	G20 at 20mbar, G30 Butane at 28-30mbar and G31 Propane at 37mbar	G20 at 20mbar, G30 Butane and G31 Propane at 30mbar	G20/G25 at 20/25mbar, G30 Butane at 28-30mbar and G31 Propane at 37mbar
Direct Country of Destination	AT, BE, BG, CH, CY, CZ, DE, DK, EE, ES, FR, FI, GE, GB, GR, HR, HU, IE, IT, IS, LT, LU, LV, MT, NL, NO, PT, RO, SE, SI, SK, TR, NL						
Nominal Heat Input	Qn=Triple burner: 3.3kW; Rapid burner: 3.0kW; Semi-rapid burner: 1.75kW; Auxiliary 1.0kW						
Total Heat Input	ΣQn=10.8 kW(787 g/h)						
Electrical Supply	220-240V~, 50Hz-60Hz, 2W						
⚠ CAUTION:							
This appliance shall be installed in accordance with the regulations in force and only used in a well ventilated space. Read the instructions before installing or using this appliance.							

Here For You

After-sales assistance

If you continue to experience problems with your Gas Hob, please call the Montpellier customer service helpline on: **01759 487839**.

Please have all your product details available, including the model number, serial number, date of purchase, and your retailer's details before registering a fault.

The service call cannot progress without this information.

Your 2 year Manufacturer's guarantee

THIS DOES NOT AFFECT YOUR STATUTORY RIGHTS.

Your new Montpellier appliance carries a free guarantee which protects you against the cost of repairs during the first 24 months from date of purchase provided that:

Any claim is accompanied by evidence of the model reference, model serial number and proof of purchase, such as a Sales Receipt, showing that the appliance was purchased within the 24 months prior to the date of claim.

What is not covered under the Guarantee

- Any appliance not correctly installed and operated in accordance with the manufacturer's instructions.
- Any appliance that is used for anything other than domestic purposes.
- Any defect caused by accident, misuse, unauthorised modification or inexpert repair.
- Cost of Call-out where a fault cannot be found with the appliance.
- Cost of Call-out for work covering routine maintenance, such as, but not exclusively, cleaning of filters or defrosting.
- Cost of Call-out for work required to correct the alignment of doors following door reversal procedures carried out by you.
- Use of the appliance by anyone other than the Householder.
- Use in any commercial environment.
- Consumable items, such as, but not exclusively, fuses in plugs, bulbs and breakable items which require routine replacement.
- Repair costs incurred that have not been authorised by Montpellier and/or carried out by a non-approved Montpellier engineer.

YOUR GUARANTEE IS VALID ONLY IN THE UK & ROI.

To register your appliance simply complete the card in your appliance pack and return it with a stamp affixed or alternatively you can register online at **www.montpellier-appliances.com/support**

SERVICE HELP-LINE

Should your appliance develop a fault, please call the Montpellier customer service helpline on: **01759 487839**.

Please remember to have all your product details available, including the model number, serial number, date of purchase and your retailer's details before registering a fault.

Your service call cannot progress without this information.

Montpellier Domestic Appliances Ltd.

Unit 1, Tewkesbury Retail Park, Northway Lane,
Tewkesbury, Gloucestershire GL20 8JU

www.montpellier-appliances.com



The symbol on the product or on its packaging indicates that this product may not be treated as household waste. Instead it shall be handed over to the applicable collection point for the recycling of electrical and electronic equipment. By ensuring this product is disposed of correctly, you will help prevent potential negative consequences for the environment and human health, which could otherwise be caused by inappropriate waste handling of this product. For more detailed information about recycling of this product, please contact your local city office, your household waste disposal service or the shop where you purchased the product.