

Montpellier

Installation and Operating Instructions

**Models: MON-DCH1060BG,
MON-DCH2160BG, MON-DCH3260BG,
MON-DCH4350BG, MON-DCH5360BG,
MON-DCH6450BG & MON-DCH7460BG**

50cm & 60cm Slanted Cooker Hoods

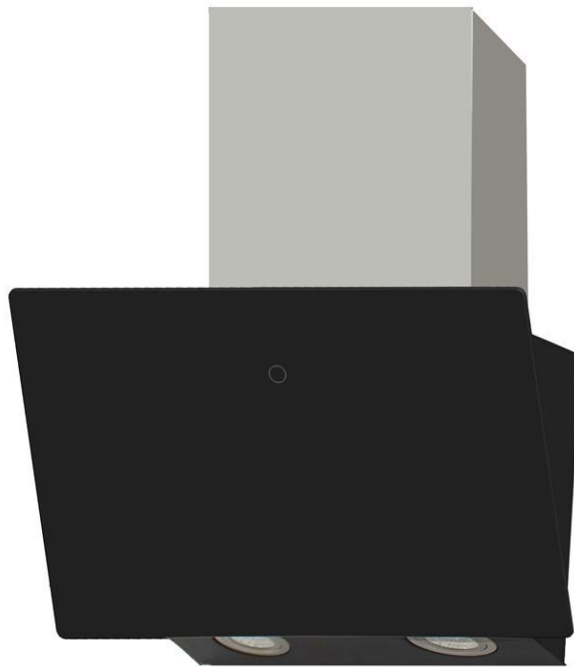

(Model shown for indicative purposes only)

Please read these instructions carefully before attempting to install or use this appliance. It is advisable to keep these instructions in a safe place for future reference. N.B. Should your appliance require attention, our service agents will not be able to book a service call without your unique serial number which can be found on the last page of this manual.

Introduction

Thank you for choosing this Montpellier appliance. It has been designed to give years of trouble-free use provided it is installed and maintained correctly.

Please read these instructions carefully before installing or using your appliance. It is advisable to keep your purchase and installation receipts with these instructions in a safe place for future reference. Included is some important safety information in addition to guidelines and recommendations that will enable you to take full advantage of all the functions available.

This quality appliance has been tested and certified to meet all applicable UK electrical and safety standards.

This appliance must be installed and connected in accordance with current regulations by a qualified electrician.

After unpacking the appliance ensure that there is no visible damage. If the appliance has been damaged during transit, do not use it, contact your retailer immediately.

Your 2 year Manufacturer's guarantee

THIS DOES NOT AFFECT YOUR STATUTORY RIGHTS.

Your new Montpellier appliance carries a free guarantee which protects you against the cost of repairs during the first 24 months from date of purchase provided that:

Any claim is accompanied by evidence of the model reference, model serial number and proof of purchase, such as a Sales Receipt, showing that the appliance was purchased within the 24 months prior to the date of claim.

What is not covered under the Guarantee:

- Any appliance not correctly installed and operated in accordance with the manufacturer's instructions.
- Any appliance that is used for anything other than domestic purposes.
- Any defect caused by accident, misuse, unauthorized modification or inexperienced repair.
- Cost of Call-out where a fault cannot be found with the appliance.
- Cost of Call-out for work covering routine maintenance, such as, but not exclusively, cleaning of filters or defrosting.
- Cost of Call-out for work required to correct the alignment of doors following door reversal procedures carried out by you.
- Use of the appliance by anyone other than the Householder.
- Use in any commercial environment.
- Consumable items, such as, but not exclusively, fuses in plugs, bulbs and breakable items which require routine replacement.
- Repair costs incurred that have not been authorised by Repairtech and/or carried out by a non-approved Repairtech engineer.

YOUR GUARANTEE IS VALID ONLY IN THE UK.

To Register your Appliance simply complete the card in your appliance pack and return it with a stamp affixed or *Alternatively* you can Register online at www.repairtechuk.com

SERVICE HELP-LINE

Should your appliance develop a fault, please call the

Repairtech Service Helpline on:

01527-888133

Please remember to have all your product details available, including the model number, serial number, date of purchase and your retailer's details before registering a fault.

Your service call cannot progress without this information.

Description of the Appliance

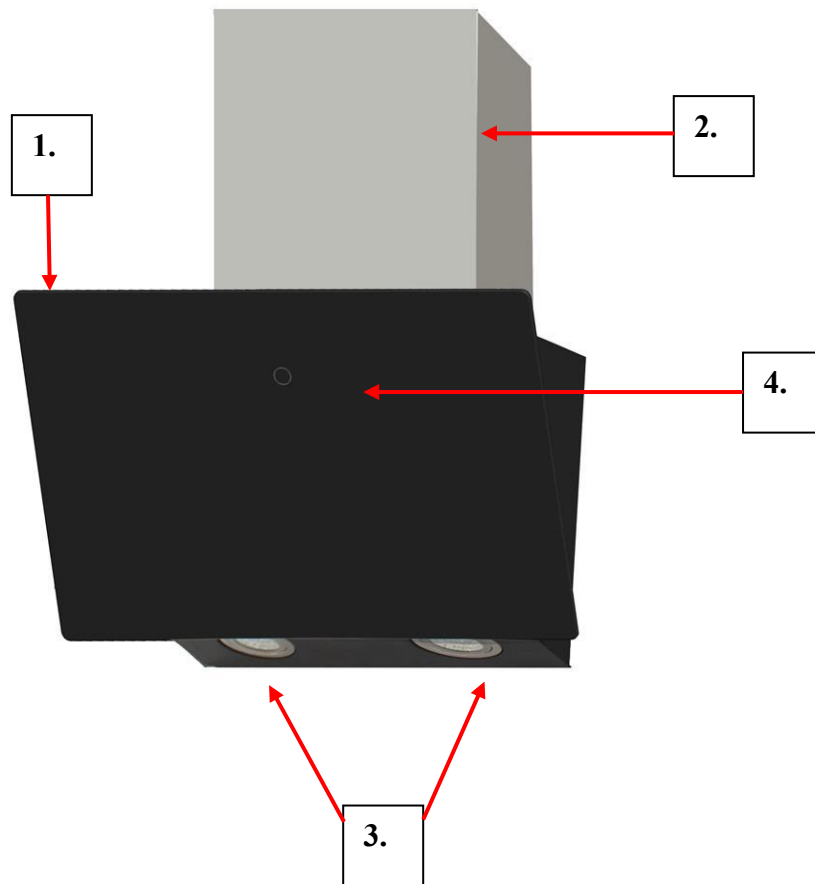

- 1. Main Body Section**
- 2. Chimney Section**
- 3. Lights**
- 4. Function Control Panel**

(Model shown for indicative purposes only)

CONTENTS:

Section 1. Installation

Section 2. Safety Advice

Section 3. Operating the Appliance

Section 4. Maintenance

Section 5. Electrical Diagram & Installation Dimensions

Section 1. Installation

N.B. Full Dimensions are shown in Section 5. (Page 14/15/16)

- A qualified installer must carry out the installation.
- This appliance can be used fully 'vented' via a ducting hose (not supplied) and external wall vent, or in 're-circulation' mode by using the charcoal filter(s) provided. **You must use a charcoal filter in re-circulation mode. Do not fit a charcoal filter when venting to the outside.**
- Position the wall bracket against the wall and mark out the position of the 3 holes. Drill 3 8mm holes and secure the bracket to the wall with the fixings supplied.

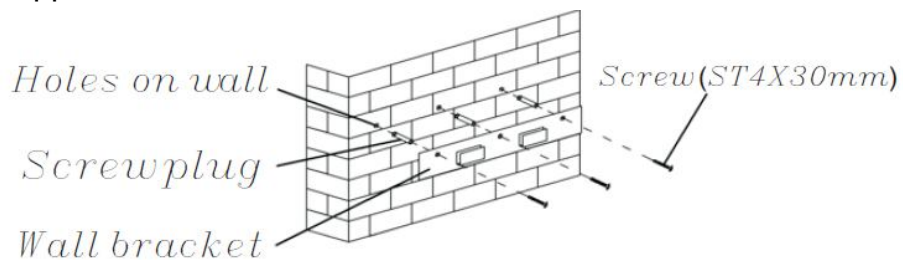

- Now drill four extra holes in line with the holes on the back of the cooker hood

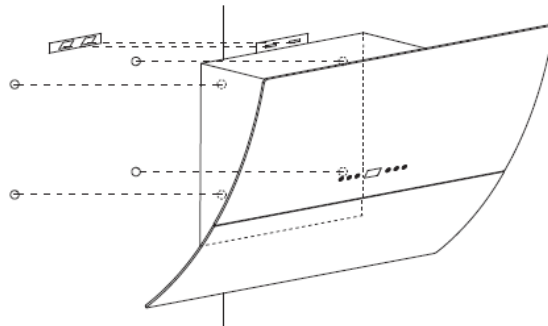

- Hang the cooker hood onto the wall bracket and secure

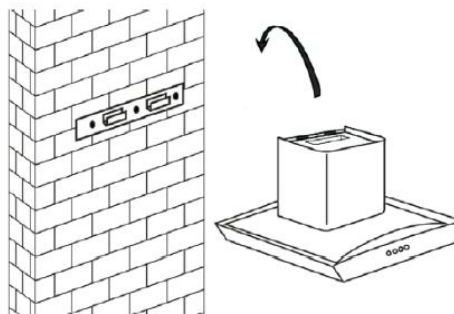

- Fit the one way valve and the flexible hose to the cooker hood

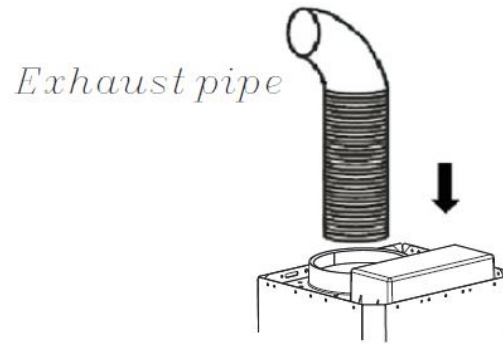

- Fit the upper chimney section to the lower chimney section and adjust to the required height

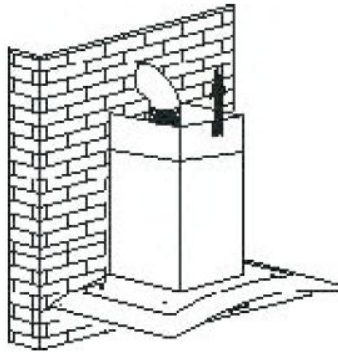

- Fit the chimney fixing plate to the wall and attach the chimney section to the plate

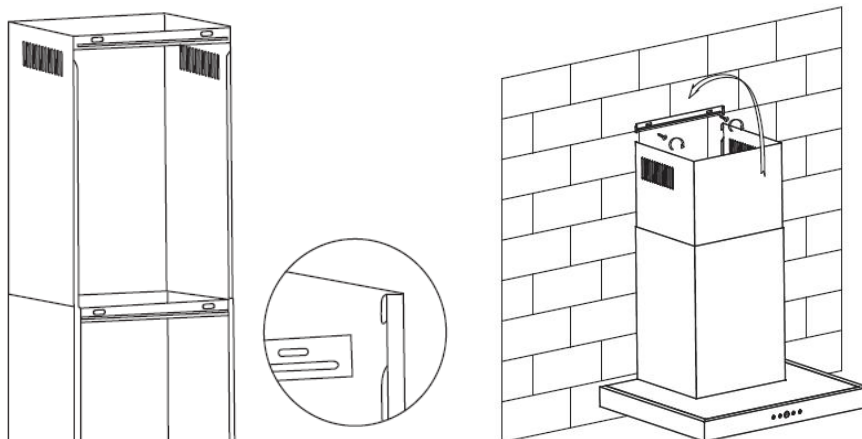

- The cooker hood should ideally be installed between 65-75cm above the work surface/cooker hob. DO NOT INSTALL BELOW 65cm.
- If you want to use this appliance fully 'vented', connect the flexible ducting hose to the one-way valve on the motor and connect the other end to the wall outlet (not supplied). Do not fit the charcoal filter! **N.B. To ensure that your cooker hood operates efficiently the hose length must not exceed 2m with a maximum of one bend.**

N.B. Your installer will supply a suitable wall outlet.

- This appliance must not share the same air outlet as another appliance, i.e. gas heating outlet.
- The mains lead should be connected to a suitably positioned fused electrical spur, protected by a 13amp fuse.
- Ensure that dust and debris is cleaned up from the immediate area of the appliance prior to it being switched on and tested for the first time.

Section 2. Safety Advice

- This appliance is manufactured and intended for DOMESTIC use only. Any guarantee offered with the appliance is not valid for any installation in a commercial environment.
- This appliance incorporates stainless steel. Handle with care as some of the edges may be sharp.
- The main filter must be cleaned on a regular basis in order to help maintain the appliance in good working order.
- Always turn off the electricity supply before cleaning the filter or the appliance exterior.
- When replacing the bulbs or charcoal filter, ensure that you fit a 'like for like' replacement.
- We recommend that this appliance is installed by a professional installer.
- This appliance shall not be used by children aged from 8 years and above and persons with reduced physical, sensory or mental capabilities, or lack of experience and knowledge, unless they have been given supervision or instruction on how to use of the appliance in a safe way and understand the hazards involved. Children shall not play with the appliance. Cleaning and user maintenance shall not be made by children without supervision.
- If the power supply cord is damaged, it must be replaced by the manufacturer, it's service agent or similarly qualified persons in order to avoid a hazard.

Section 3. Operating the Appliance

3.1. Touch Controls

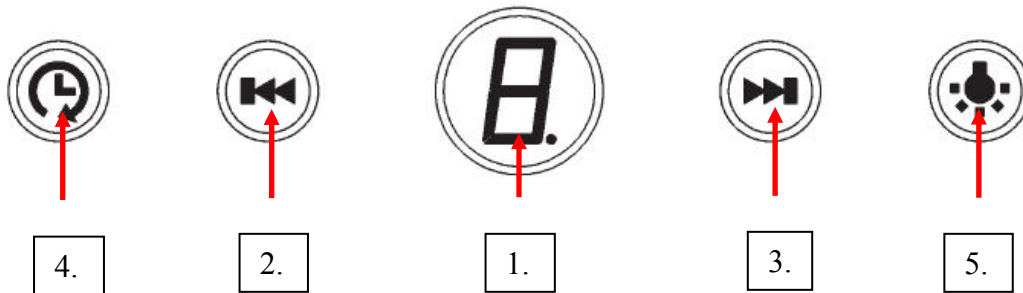

1. Digital On/Off & Display Key
2. Power Down Key
3. Power Up Key
4. Delay Key
5. Lights – On/Off

3.2. Push Button Controls

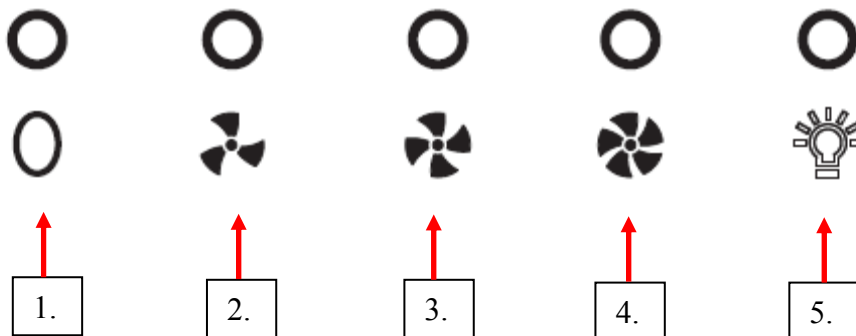

1. On/Off Button
2. Slow Speed Fan
3. Middle Speed Fan
4. High Speed Fan
5. Lights – On/Off

For best results, we recommend that the Cooker Hood is switched on at least 10 minutes prior to cooking and left to run for a period of 10 minutes after cooking is finished.

3.3. To Operate:

- Press the Digital On/Off & Display key or On/Off Button to switch the unit on.
- Control the fan speed by pressing the Power Up and Power Down keys or the Fan Speed buttons.
- Turn the lights on and off by using the Lights key or On/Off button.
- On 'Touch Control' models only, press the Delay key repeatedly to operate the delay function between 1 and 10 minutes. When activated, the display will flash and at the end of the set time, the unit will switch off automatically. If you have not used the Delay function, ensure that you turn the unit (and lights) off after use.
- Always ensure that you have turned the appliance off after use.
- N.B. On 'Touch Control' models, if you switch the unit on but do not touch any of the other keys within 2 minutes, the unit will automatically switch itself off.

Section 4. Maintenance

4.1. Cleaning the Main Filters

Pull the 'slanted' section of the cooker hood towards you to expose the aluminium filter(s). Periodically remove the aluminium filter covers and wash with warm soapy water. Ensure the filters are dry before re-fitting.

The main body of the cooker hood should be cleaned with warm soapy water – never use abrasive detergents on either the filter or main body.

4.2. Replacing the LED Bulbs

To replace an LED bulb, isolate the power, remove the light cover(s) and remove the bulb. Replace it with the same type/wattage (1.5W LED) and replace the light cover.

4.3. Replacing the Charcoal Filter(s)

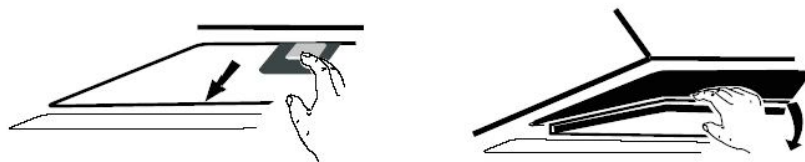

*Plug the activated carbon filter into the unit and turn it in clockwise direction.
Repeat the same on the other side.*



Make sure the filter is 'locked' into position and note that suction power is lowered when using carbon filters.

4.4. What to do if something goes wrong

One of the light bulbs does not work:

- The bulb has probably blown. Replace the bulb as referred to in Section 4.2. Please note that light bulbs are not covered by any guarantee offered with this appliance.

Motor operates but level of extraction appears to be poor:

- Check and clean the filter as detailed in Section 4.1. Dirty filters will cause a noticeable drop in performance. If you are using the appliance on 're-circulation' mode the charcoal filter may require changing as detailed in Section 4.3.

There is no power to the appliance:

- Check there is not a power cut
- Check there is power to the electric socket/appliance
- Check the fuse in the plug and/or spur (Must be 13amp)

YOUR GUARANTEE IS VALID ONLY IN THE UK.

To Register your Appliance simply complete the card in your appliance pack and return it with a stamp affixed or *Alternatively* you can Register online at www.repairtechuk.com

SERVICE HELP-LINE

Should your appliance develop a fault, please call the

Repairtech Service Helpline on:

01527-888133

Please remember to have all your product details available, including the model number, serial number, date of purchase and your retailer's details before registering a fault.

Your service call cannot progress without this information.

DOMESTIC APPLIANCE DISTRIBUTORS;
HENRY JOHN HOUSE
NORTHWAY LANE
ASHCHURCH
TEWKESBURY
GLOUCESTERSHIRE
GL20 8JH

Section 5. Electrical Diagram & Installation Dimensions

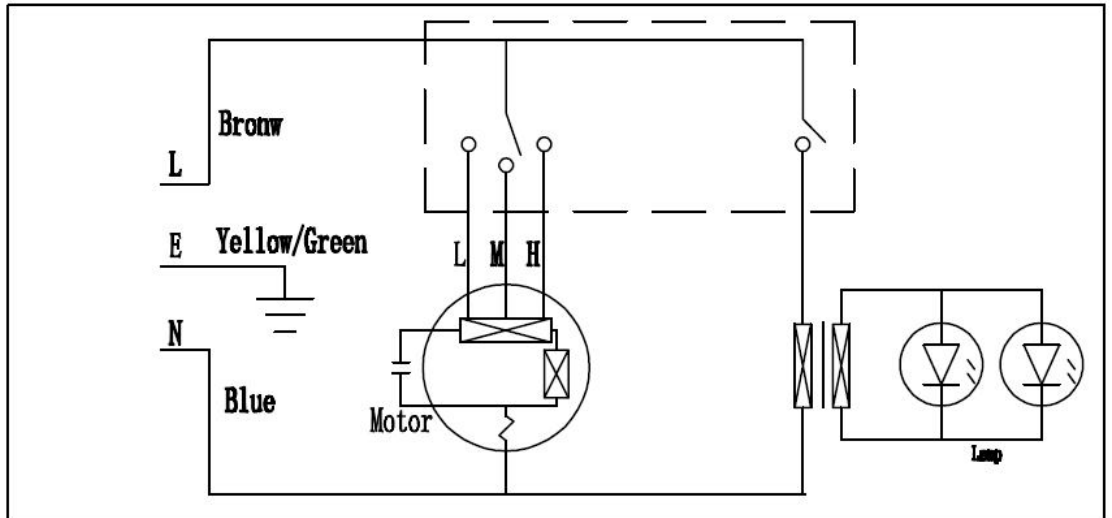

MON-DCH1060BG

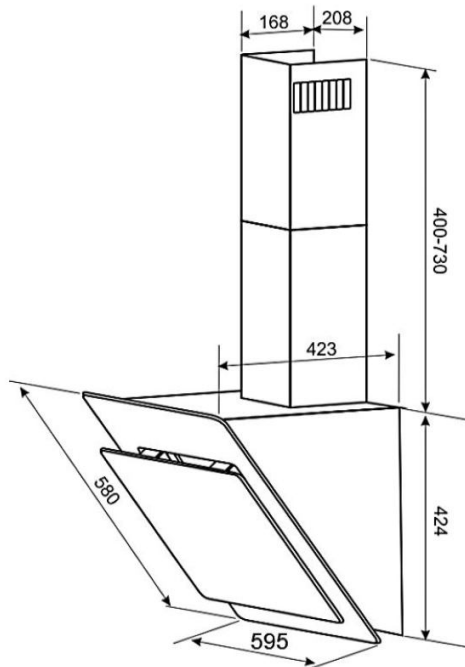

MON-DCH2160BG

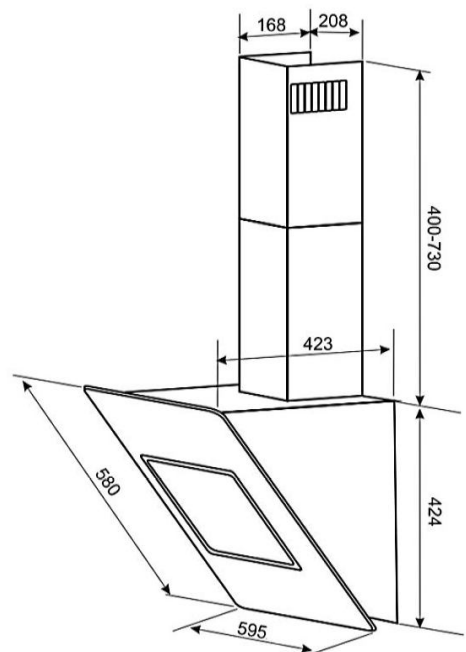

MON-DCH3260BG

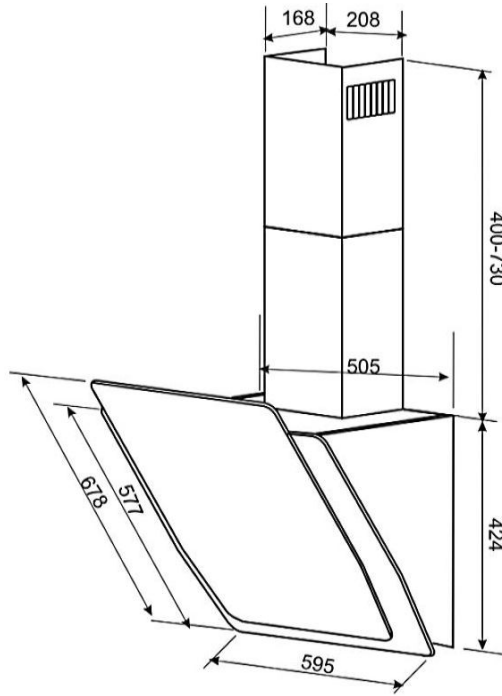

MON-DCH4350BG

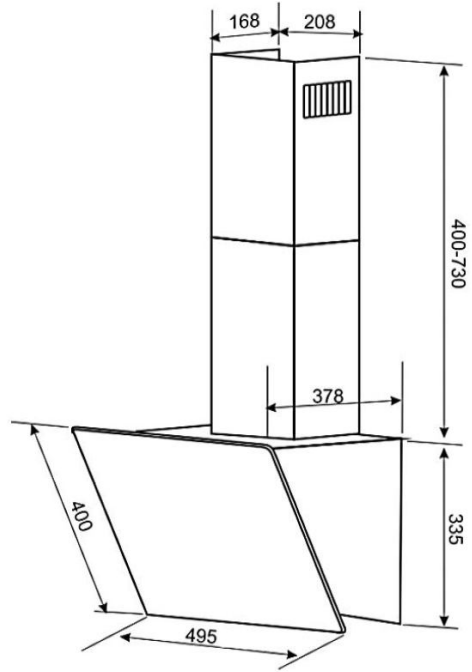

MON-DCH5360BG

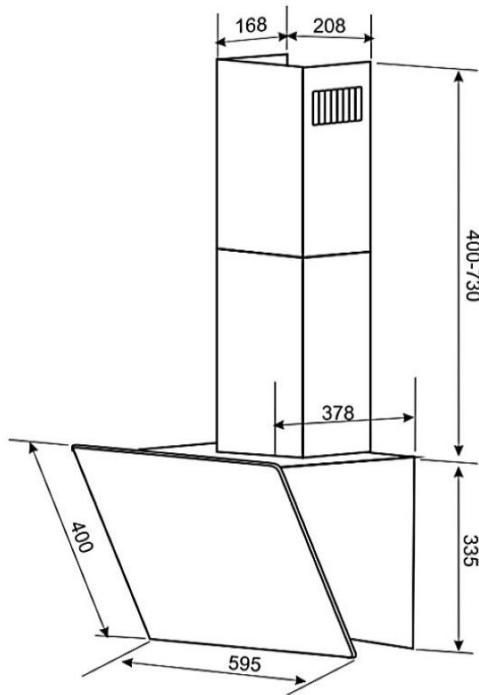

MON-DCH6450BG

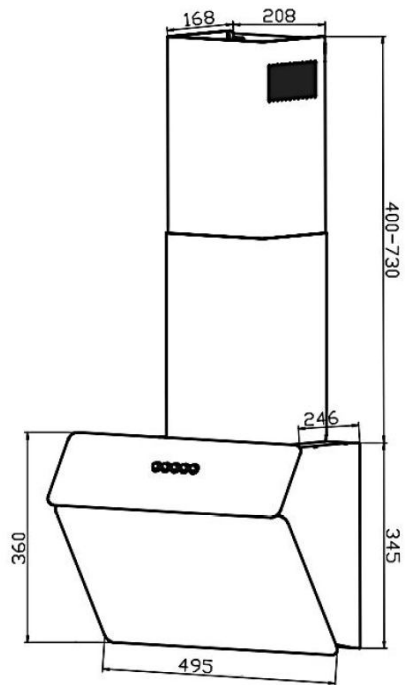

MON-DCH7460BG

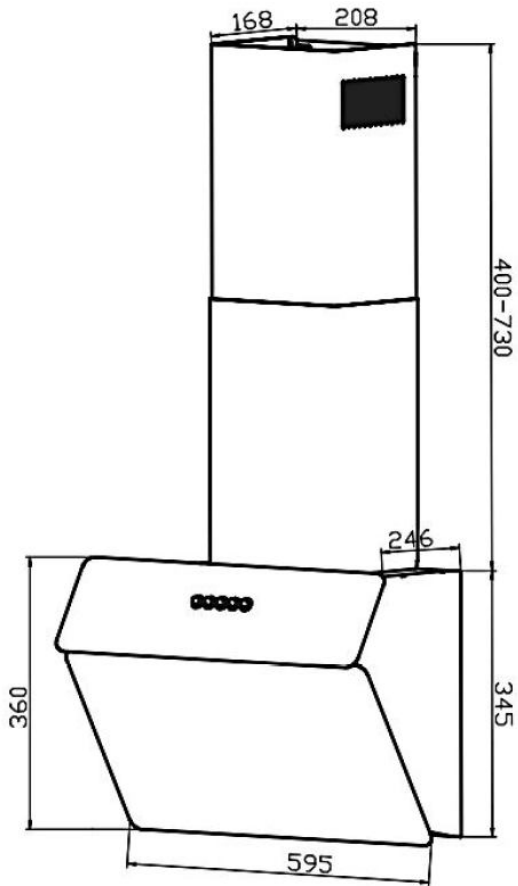

Important Note:

This appliance is marked according to the European directive 2002/96/EC on Waste Electrical and Electronic Equipment (WEEE). By ensuring this product is disposed of correctly, you will help prevent potential negative consequences for the environment and human health, which could otherwise be caused by inappropriate waste handling of this product.

The symbol on the product, or on the documents accompanying the product, the Crossed Out Wheelie Bin, indicates that this appliance may not be treated as household waste. Instead it shall be handed over to the applicable collection point for the recycling of electrical and electronic equipment.

Disposal must be carried out in accordance with local environmental regulations for waste disposal. For more detailed information about treatment, recovery and recycling of this product, please contact your local authority, your household waste disposal service or the retailer where you purchased the product.



We continuously try to improve our products for the benefit of our customers. For this reason we reserve the right to make changes to any product at any time, without notice

Issue: 04/25-07-2016