

Montpellier

THE PERFECT BALANCE OF FUNCTION AND STYLE

LAUNDRY - DISHWASHING - COOKING - COOLING

Installation and Operating Instructions



Freestanding 46 Bottle Wine Cooler

WS46SDX - 60cm Wide - Stainless Steel

Please read these instructions carefully before attempting to install or use this appliance.
We recommend that you keep these instructions in a safe place for future reference.

Description Of The Appliance

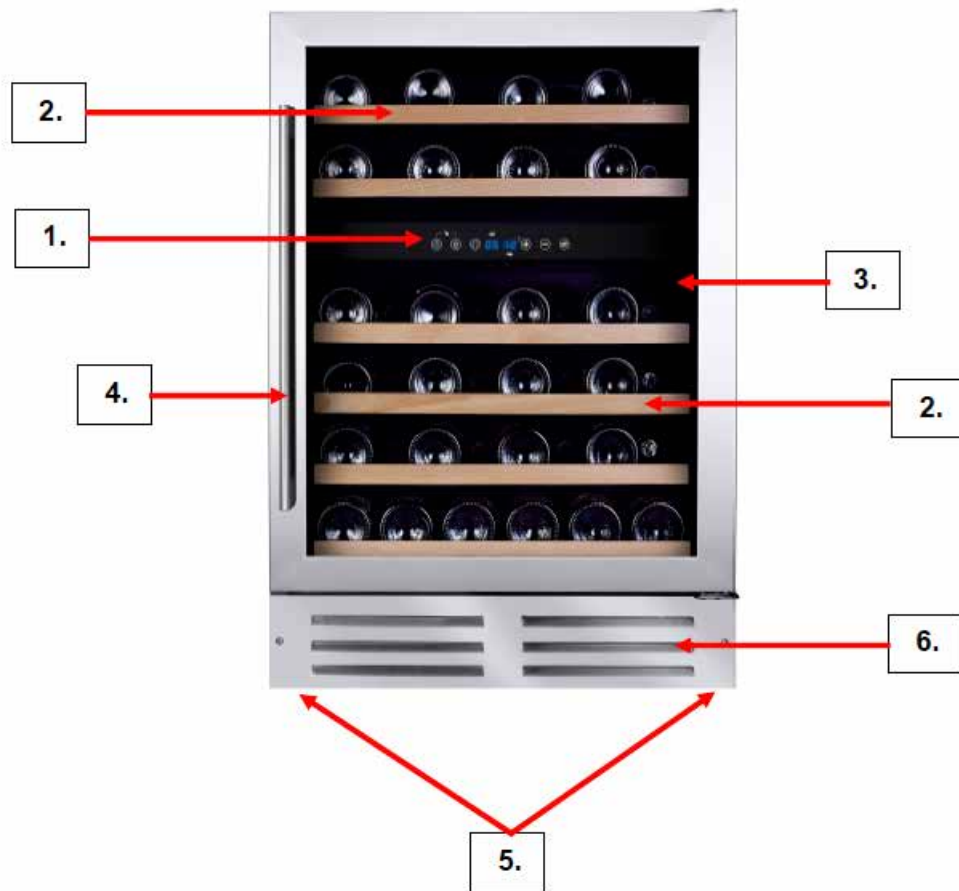

This diagram is only for informative purposes about parts of the appliance. Parts may vary according to the appliance mode.

1. Control Panel & LED Display
2. Shelves (x 6)
3. Tempered Glass Door
4. Door Handle
5. Levelling Feet
6. Ventilation Panel

Introduction and 2 Year Guarantee

Thank you for choosing this Montpellier appliance.

It has been designed to give years of trouble-free use provided it is installed and maintained correctly.

N.B. This appliance is intended to be used exclusively for the storage of wine and is for DOMESTIC USE ONLY and specifically excludes, but is not limited to use in Wine Bars, Pubs, Restaurants, Guest Houses, Hotels and Catering Services.

Please read these instructions carefully before installing or using your appliance. It is advisable to keep your purchase and installation receipts with these instructions in a safe place for future reference. Included is some important safety information in addition

to guidelines and recommendations that will enable you to take full advantage of all the functions available.

This quality appliance has been tested and certified to meet all applicable UK electrical and safety standards.

This appliance must be installed and connected in accordance with current regulations by a qualified electrician.

After unpacking the appliance ensure that there is no visible damage. If the appliance has been damaged during transit, do not use it, contact your retailer immediately.

THE 2 YEAR MANUFACTURERS GUARANTEE DOES NOT AFFECT YOUR STATUTORY RIGHTS.

Your new Montpellier appliance carries a free guarantee which protects you against the cost of repairs during the first 24 months from date of purchase provided that:

Any claim is accompanied by evidence of the model reference, model serial number and proof of purchase, such as a Sales Receipt, showing that the appliance was purchased within the 24 months prior to the date of claim.

What is not covered under the Guarantee:

- Any appliance not correctly installed and operated in accordance with the manufacturer's instructions.
- Any appliance that is used for anything other than domestic purposes.
- Any defect caused by accident, misuse, unauthorized modification or inexpert repair.
- Cost of Call-out where a fault cannot be found with the appliance.
- Cost of Call-out for work covering routine maintenance, such as, but not exclusively, cleaning of filters or defrosting.
- Cost of Call-out for work required to correct the alignment of doors following door reversal procedures carried out by you.

- Use of the appliance by anyone other than the Householder.
- Use in any commercial environment.
- Consumable items, such as, but not exclusively, fuses in plugs, bulbs and breakable items which require routine replacement.
- Repair costs incurred that have not been authorised by Montpellier Service.
- Repairs carried out by a non-approved Montpellier Service engineer.

YOUR GUARANTEE IS VALID ONLY IN THE UK & ROI.

To Register your Appliance

Simply complete the card in your appliance pack and return it with a stamp affixed or alternatively you can register online (please see link below).

Service Helpline

Should your appliance develop a fault, please call Montpellier Service on: **01759 487839**.

Please remember to have all your product details available, including the serial number, before registering a fault.

Your service call cannot progress without this information.

Register your product online
www.montpellier-appliances.com/support/register-your-product

Contents

Section 1 : Safety Advice	4
Section 2: Installation	5
Section 3: Operating The Appliance	6 - 7
Section 4: Maintenance	8

Section 1: Safety Advice

- Please read this booklet thoroughly before installing and switching on the appliance. The manufacturer accepts no responsibility for incorrect installation and usage.
- If this appliance is to replace an old refrigerator with a lock; as a safety measure break or remove the lock and/or door before disposal.
- Your old appliances contain insulation gases and refrigerant that must be disposed of correctly. Please ensure that the refrigerant circuit is not damaged before the appliance is taken away for correct disposal in line with current legislation. If there is any doubt contact your Local Authority for instructions.
- This appliance may contain the refrigerant isobutene (R600a). This is a natural gas with a high level of environmental compatibility; however, caution is required as isobutene is a flammable gas. It is essential to ensure that refrigerant tubes are not damaged during transportation and the installation of the appliance. In the event that the refrigerant circuit is damaged, avoid naked flames or sources of ignition and ventilate the room in which the appliance is situated.
- Do not damage the refrigerant circuit.
- The appliance shall not be used by children aged from 8 years and above and persons with reduced physical, sensory or mental capabilities, or lack of experience and knowledge, unless they have been given supervision or instruction on how to use the appliance in a safe way and understand the hazards involved. Children shall not play with the appliance. Cleaning and user maintenance shall not be made by children without supervision.
- Do not allow children to play with the appliance. Children must never play in or around the appliance.
- If using an adaptor, this must be used in accordance with the manufacturer's instructions and ensure that the electrical circuit is not overloaded as this could cause overheating.
- Do not twist or bend the cables, and keep them away from hot surfaces.
- Do not plug in or unplug this appliance with wet hands.
- Following installation make sure that the power cable is not trapped underneath the appliance.
- If the power supply cord is damaged, it must be replaced by the manufacturer, it's service agent or similarly qualified persons in order to avoid a hazard.

Section 2: Installation

This appliance is intended to be used exclusively for the storage of wine.

This appliance is designed for domestic use only and should be operated in ambient temperatures (surrounding air temperature) between 16°C and 32°C (61-90°F). If these temperatures are exceeded i.e. colder or warmer, the appliance will not operate correctly.

2.1. Before Use

Remove all securing tapes. Wash the inside of the appliance with lukewarm water with a little bicarbonate of soda added (5ml to 0.5 litre of water). Do not use soap or detergent as the smell may linger. Dry the appliance thoroughly.

1.2. Installing the Door Handle

- Carefully ease the door seal to one side
- Attach the door handle using the two screws
- Ease the door seal back into place

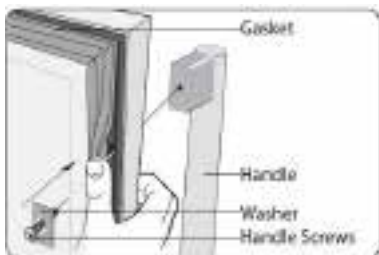

1.3. Installation & Ventilation Requirements

To ensure correct operation this appliance must not be located where the temperatures may fall below 16°C or rise above 32°C. Avoid the following locations: unheated kitchen, outhouse, conservatory, garage. For correct operation this appliance must be installed:

- In a dry atmosphere
- Out of direct sunlight.
- Away from extreme temperature (not next to a cooker or other sources of heat)

Ensure the following points are observed during installation:

- The appliance must be placed on a strong floor
- The appliance must be level. Adjust the level by screwing the adjustable foot up or down (use your fingers or a suitable spanner)
- The appliance must be upright and in firm contact with the floor so that the cabinet is stable.
- You must ensure that the Front Ventilation Panel remains clear.

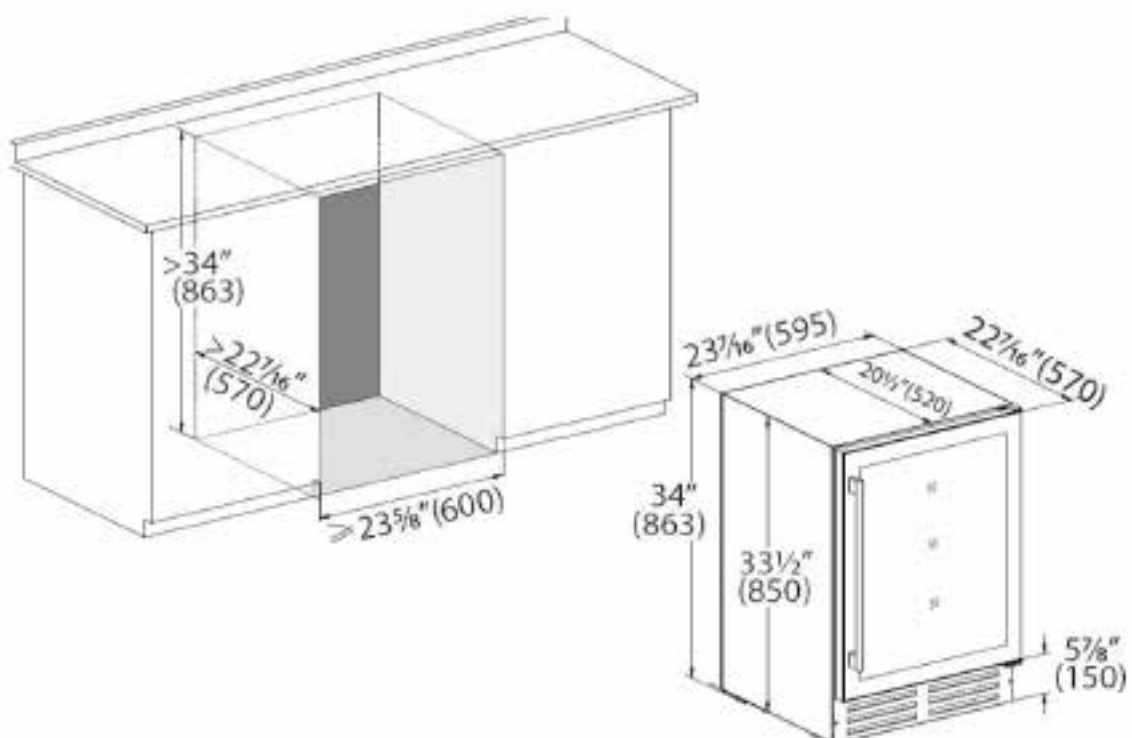

Section 3: Operating The Appliance

3.1. Switching on the Appliance

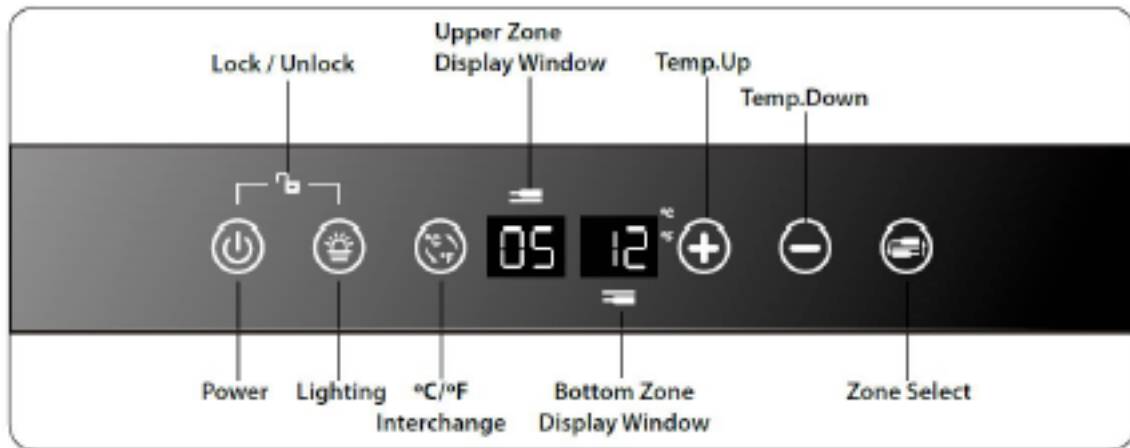

- Allow the appliance to stand for a minimum of 4 hours after installation.
 - Plug in the appliance and switch on at the mains supply.
 - Press and hold the Power button for 10 seconds (To turn the unit off, simply press and hold the Power button for 10 seconds).
 - Set the temperature control to the required setting as detailed in the Temperature Control section.
 - Leave the appliance for approximately 4 hours for the correct temperature to be reached.
 - To lock the control panel, press and hold the Power & Lighting buttons for 3 seconds. (Press and hold for 3 seconds to de-activate).
- Please note that this is a wine cooler and not a fridge. This appliance is intended to be used exclusively for the storage of wine. The interior of this appliance will not get as cold as a fridge – it is designed to maintain wines at the correct temperature. The temperature range is 2°– 12°C (36–54°F) for the Upper Zone and 12°– 20°C (54–68°F) for the Lower Zone.
- Press the °C/°F Interchange button to change between Fahrenheit (°F) & Celsius (°C).
 - Press the 'Lighting' button to turn on or turn off the interior light.
 - Select the Zone by pressing the 'Zone Select' button.
 - Adjust the temperature by pressing '+' or '-'.
 - After approximately 10 seconds, the display will revert to showing the current temperature inside the cabinet. N.B. It will take a period of time for the appliance to reach the actual required temperature following the setting or adjustment of the temperature on the control panel.

3.2. Temperature Control

Section 3: Operating The Appliance

3.3. Normal Operating Sounds

You may hear faint gurgling or bubbling sounds when the refrigerant is pumped to the cooling system and through the coils or tubing at the rear of the appliance. When the compressor is in operation you may hear a slight whirring sound or pulsating noise. The thermostat controls the operation of the compressor, and you may hear a slight click as it cycles in and out.

3.4. Energy Saving Advice

Do not install the appliance close to sources of heat, such as a cooker, dishwasher or radiator. Locate the appliance in a cool well-ventilated room and make sure that the air vents are clear.

Try to avoid keeping the door open for long time, warm air will enter the cabinet, and may cause condensation as well as affecting the energy consumption. Ensure there are no obstructions preventing the door from closing properly

3.5. In the Event of a Power Failure

If there is a power failure, keep the door closed. When the power has been restored the appliance will start to operate but it may take some time to achieve the pre-set operating temperature.

Section 4: Maintenance

Before any maintenance or cleaning work is carried out, DISCONNECT the appliance from the ELECTRICITY supply.

4.1. Internal Cleaning

Clean the inside and accessories with warm water and bicarbonate of soda (5ml to 0.5 litre of water). Rinse and dry thoroughly. Do not use detergents, abrasive powders, highly perfumed cleaning products, wax polishes or cleaning products containing bleach or alcohol.

4.2. External Cleaning

Wash the outer cabinet with warm soapy water. Do NOT use abrasive products. There may be sharp edges on the underside of the product, so care should be taken when cleaning. Once or twice a year dust the condenser (black grille) and the compressor at the back of the appliance, with a brush or vacuum cleaner, as an accumulation of dust will affect the performance of the appliance and cause increased energy consumption.

4.3. When the appliance is not in use

When the appliance is not in use for long periods, i.e. nothing is being stored in the appliance, disconnect from the electricity supply, clean the appliance, leaving the door ajar until you wish to use the appliance again.

4.4. What to do if something goes wrong

There is no power to the appliance:

- Check there is not a power cut
- Check there is power to the electric socket/appliance
- Check the fuse in the plug (Must be 13 amp)
- Check that the Temperature Control has been set correctly (section 3.2.)

The compressor runs continuously:

- Is the door closed correctly?
- Have large quantities of bottles recently been added to the appliance? –if yes, allow the interior temperature to recover
- Has the appliance door been opened frequently? – if yes, allow the interior temperature to recover
- Check that the Temperature Control has not been set to maximum

There is excessive condensation and/or frost build-up:

- Ensure that the door has been closed correctly
- Ensure that the door seal is clean and sealing correctly
- Check that the Temperature Control has not been set to maximum

The appliance is making a noise:

- Refer to Normal Operating Sounds, section 3.3.
- Ensure that the appliance has been installed correctly (see section 2)

Notes

Notes

Help-line

If after the previous checks there is still a fault, please contact the Montpellier Service Help-line below.

Please ensure that you have the model number, serial number, date of purchase and retailers information available before you make the call.

Service Help-Line

Should your appliance develop a fault, please call Montpellier Service on: **01759 487839**.

Electrical connection (for UK type plug)

For your safety please read the following information.
Warning: This appliance must be earthed.

This appliance operates from 220-240 volts and should be protected by a 13amp fuse in the plug.

The appliance is supplied with a standard 13 amp 3-pin mains plug fitted with a 13-amp fuse. Should the fuse require replacement, it must be replaced with a fuse rated at 13 amp and approved to BS1362.

Insurance

The warranty provided with this product does not cover loss of food or wine content.

Any claim for loss, damage, costs or expenses of an indirect or consequential nature including any economic loss or damage to foodstuffs or any other goods is excluded. We recommend that you inspect your appliance regularly to check that it is working correctly, losses can result from deterioration following breakdown or accidental failure of the appliance, fuses, plugs or public electricity supply, these can be covered by your standard home insurance or might require extra cover. Check with your insurance provider.

Important Note:

This appliance is marked according to the European directive 2002/96/EC on Waste Electrical and Electronic Equipment (WEEE). By ensuring this product is disposed of correctly, you will help prevent potential negative consequences for the environment and human health, which could otherwise be caused by inappropriate waste handling of this product.

The symbol on the product, or on the documents accompanying the product, the Crossed Out Wheelie Bin, indicates that this appliance may not be treated as household waste. Instead it shall be handed over to the applicable collection point for the recycling of electrical and electronic equipment.

Disposal must be carried out in accordance with local environmental regulations for waste disposal. For more detailed information about treatment, recovery and recycling of this product, please contact your local authority, your household waste disposal service or the retailer where you purchased the product.



Montpellier

THE PERFECT BALANCE OF FUNCTION, STYLE AND RELIABILITY

LAUNDRY - DISHWASHING - COOKING - COOLING

We continuously try to improve our products for the benefit of our customers. For this reason we reserve the right to make changes to any product at any time, without notice

Issue: 01/11/18

Montpellier Domestic Appliances Ltd.

Unit 1, Tewkesbury Retail Park, Northway Lane,
Tewkesbury, Gloucestershire GL20 8JU

www.montpellier-appliances.com



The symbol on the product or on its packaging indicates that this product may not be treated as household waste. Instead it shall be handed over to the applicable collection point for the recycling of electrical and electronic equipment. By ensuring this product is disposed of correctly, you will help prevent potential negative consequences for the environment and human health, which could otherwise be caused by inappropriate waste handling of this product. For more detailed information about recycling of this product, please contact your local city office, your household waste disposal service or the shop where you purchased the product.