

montpellier

Installation and Operating Instructions

**MODELS: MR90GOK, MR90GOX,
RMC90GOK & RMC90GOC**

90cm Range Cooker – Gas

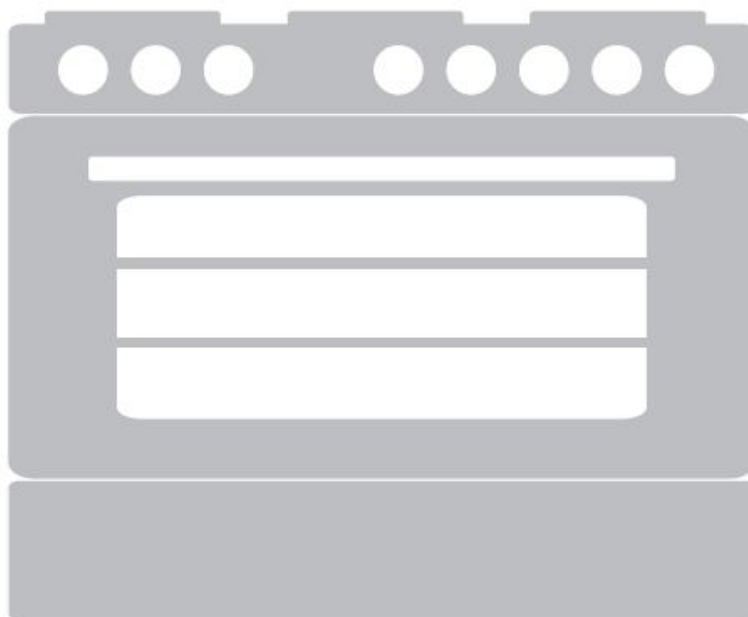

(Picture indicative of model supplied)

Please read these instructions carefully before attempting to install or use this appliance.

It is advisable to keep these instructions in a safe place for future reference.

N.B. Should your appliance require attention, our service agents will not be able to book a service call without your unique serial number which can be found on the last page of this manual.

Introduction

Thank you for choosing this **montpellier** branded appliance. It has been designed to give years of trouble-free use provided it is installed and maintained correctly.

Please read these instructions carefully before installing or using your appliance. It is advisable to keep your purchase and installation receipts with these instructions in a safe place for future reference. Included is some important safety information in addition to guidelines and recommendations that will enable you to take full advantage of all the functions available.

This quality appliance has been tested and certified to meet all applicable UK electrical and safety standards.

This appliance must be installed and connected in accordance with current regulations.

After unpacking the appliance ensure that there is no visible damage. If the appliance has been damaged during transit, do not use it, contact your retailer immediately.

Your 2 year Manufacturer's guarantee

THIS DOES NOT AFFECT YOUR STATUTORY RIGHTS.

Your new **montpellier** appliance carries a free guarantee which protects you against the cost of repairs during the first 24 months from date of purchase provided that:

Any claim is accompanied by evidence of the model reference, model serial number and proof of purchase, such as a Sales Receipt, showing that the appliance was purchased within the 24 months prior to the date of claim.

What is not covered under the Guarantee:

- Any appliance not correctly installed and operated in accordance with the manufacturer's instructions.
- Any appliance that is used for anything other than domestic purposes.
- Any defect caused by accident, misuse, unauthorized modification or inexperienced repair.
- Cost of Call-out where a fault cannot be found with the appliance.
- Cost of Call-out for work covering routine maintenance, such as, but not exclusively, cleaning of filters or defrosting.
- Cost of Call-out for work required to correct the alignment of doors following door reversal procedures carried out by you.
- Use of the appliance by anyone other than the Householder.
- Use in any commercial environment.
- Consumable items, such as, but not exclusively, fuses in plugs, bulbs and breakable items which require routine replacement.
- Repair costs incurred that have not been authorised by Repairtech and/or carried out by a non-approved Repairtech engineer.

YOUR GUARANTEE IS VALID ONLY IN THE UK.

To Register your Appliance simply complete the card in your appliance pack and return it with a stamp affixed or *Alternatively* you can Register online at www.repairtechuk.com

SERVICE HELP-LINE

Should your appliance develop a fault, please call the Repairtech Service Helpline on:

01527-888133

Please remember to have all your product details available, including the model number, serial number, date of purchase and your retailer's details before registering a fault.

Your service call cannot progress without this information.

Description Of The Appliance

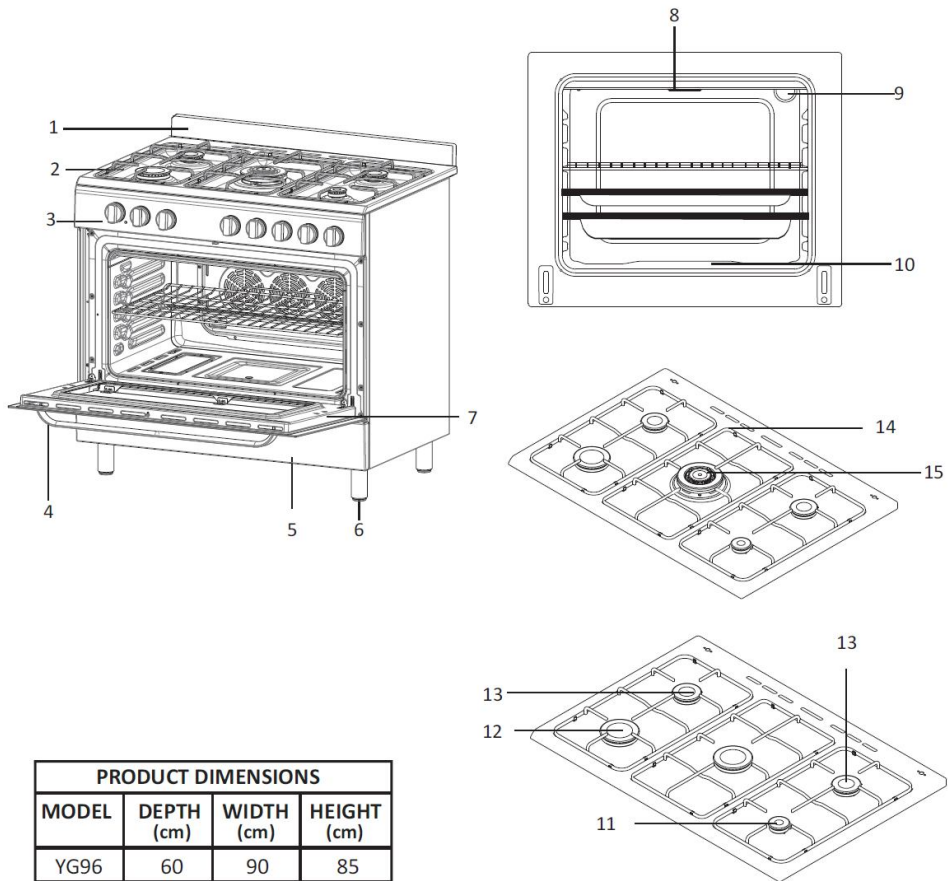

PRODUCT DIMENSIONS			
MODEL	DEPTH (cm)	WIDTH (cm)	HEIGHT (cm)
YG96	60	90	85

- | | | |
|-----------------------|------------------|--------------------------|
| 1. Splash-back | 2. Hotplate | 3. Control Panel |
| 4. Door Handle | 5. Storage Cover | 6. Adjustable Feet (x 4) |
| 7. Oven Door | 8. Grill Burner | 9. Oven Light |
| 10. Oven Burner | 11. Small Burner | 12. Rapid Burner |
| 13. Semi Rapid Burner | 14. Pan Support | 15. Wok Burner |

(Please note that the drawings used in this manual are schematic and may vary from the actual model Supplied. In addition, the model supplied may not have all of the features shown/described in this manual).

CONTENTS:

Section 1. Installation

Section 2. Safety Advice

Section 3. Operating the Appliance

Section 4. Maintenance

Section 1. Installation

- Remove all packaging, protective film and securing tape from the appliance.
- Position the appliance in a dry atmosphere.
- The following dimensions are provided as a guide for installation – your installer will carry out the installation in accordance with the current regulations.
- Your installer will connect the power cable in accordance with the current regulations.

1.1. Positioning the Appliance

- Position the appliance as shown in the diagram below.
- Ensure an air gap of at least 2cm on all sides of the appliance.
- You must ensure a minimum gap of 65cm between the top of the appliance and a cooker hood. The gap must be 70cm if there is no cooker hood installed above the appliance.

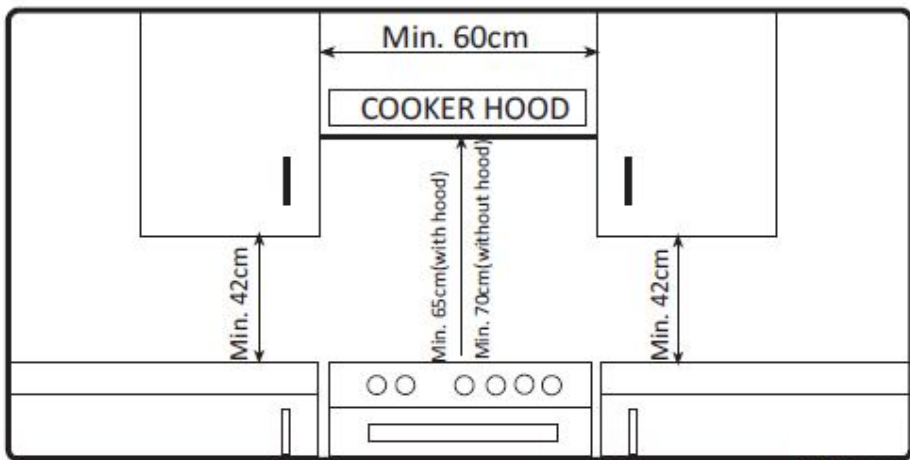

1.2. Electrical Connection

This appliance can be fitted with a 13 Amp plug and plugged into a standard, switchable 13 Amp socket.

Please note that if you use a socket directly behind the appliance, a switchable spur should be accessible above the work surface in order that the power can be turned off.

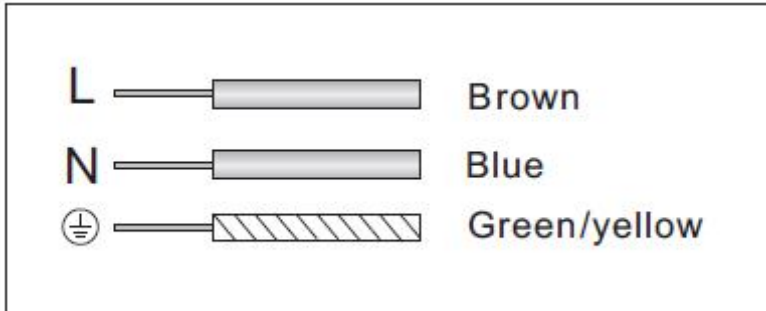

1.3. Gas Connection

This appliance must be installed by a 'Gas Safe' engineer.

Your approved 'Gas Safe' engineer will ensure that your appliance is connected in accordance with the current regulations.

1.4. Level the Appliance

Finally, ensure that the appliance is level by adjusting the 4 feet as shown below.

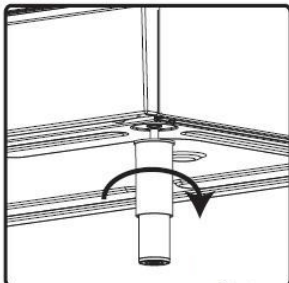

Section 2. Safety Advice

- **This appliance must be installed by a 'Gas Safe' engineer.**
- Please read this booklet thoroughly before installing and switching on the appliance. The manufacturer accepts no responsibility for incorrect installation and usage.
- This appliance is guaranteed for Domestic Use Only.
- The appliance is not intended for use by persons (including children) with reduced physical, sensory or mental capabilities, or lack of experience and knowledge, unless they have been given supervision or instruction concerning the use of the appliance by a person responsible for their safety. Children should be supervised to ensure that they do not play with the appliance.
- This appliance must only be used for cooking/heating food items. Do not use it for any other purpose.
- If using an adaptor, this must be used in accordance with the manufacturers instructions and ensure that the electrical circuit is not overloaded as this could cause overheating.
- Do not twist or bend the cables, and keep them away from hot surfaces.
- Following installation make sure that the power cable is not trapped underneath the appliance.
- Keep the appliance surfaces clean. Failure to do this could lead to the appliance malfunctioning.
- The surface of this appliance will get extremely hot during use. Take care when using the appliance and keep children well away.
- The interior and surface of this appliance will remain hot after it has been turned off. Do not touch or clean the appliance until it has completely cooled down.
- Never lift this appliance using the door handle or 'open' door.
- If the power supply cord is damaged, it must be replaced by the manufacturer, it's service agent or similarly qualified persons in order to avoid a hazard.

Section 3. Operating the Appliance

3.1. Oven Control Panel

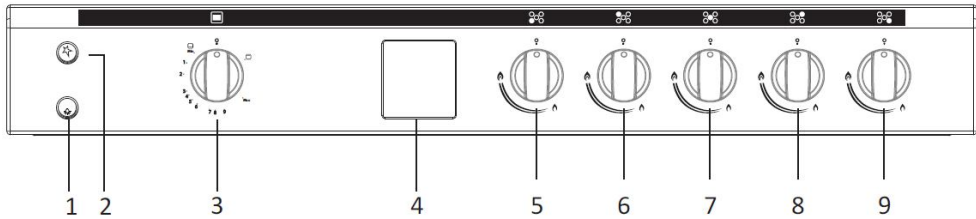

1. Oven Light Button
2. Ignition Button
3. Oven & Grill Control Knob
4. Minute Minder
5. Front Left Hotplate Burner Control Knob
6. Rear Left Hotplate Burner Control Knob
7. Centre Hotplate Burner Control Knob
8. Rear Right Hotplate Burner Control Knob
9. Front Right Hotplate Burner Control Knob

3.2. Cooking & Functions

3.2.1. Operating the Hotplate

- Press and turn the appropriate Burner Control Knob to the 'MAX' heat setting (see diagram below).
- Keep the control knob pressed in.
- Now press the Ignition Button until the burner ignites.
- Once the burner is alight, release the Ignition Button and turn the Burner Control Knob to the required heat setting.
- Turn the Burner Control Knob(s) to the 'Off' position when you have finished.

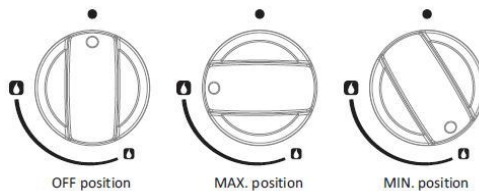

3.2.2. Operating the Grill

- Fit the heat shield to the underside of the Control Panel prior to using the grill (See picture below).
- Once in place, close the oven door until it just touches the heat shield (See picture below).

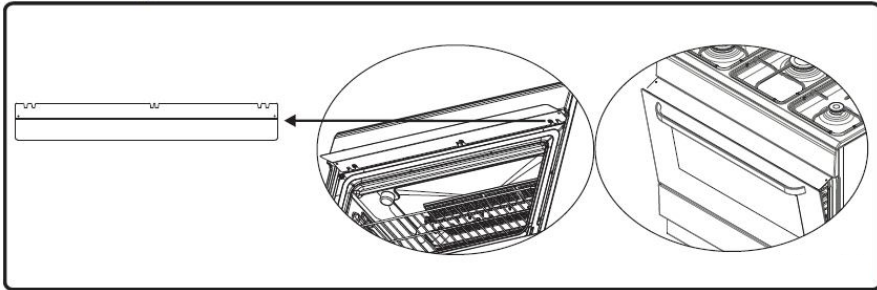

- Press and Turn the Oven/Grill Control Knob to the Grill Position.
- Keep the control knob pressed in.
- Now press the Ignition Button until the burner ignites.
- Turn the Burner Control Knob back to the 'Off' position when you have finished.

3.2.3. Operating the Oven

- Press and turn the Oven Function Control Knob to the Minimum setting.
- Keep the control knob pressed in.
- Now press the Ignition Button until the burner ignites.
- Please note that you may need to keep the control knob pressed in for up to 30 seconds to allow the flame failure device to activate fully.
- If the flame goes out, wait 90 seconds before repeating the ignition procedure.
- Once the burner is fully lit, turn the Control Knob to the required thermostat setting. (See Section 3.2.4. for table).
- Turn the Control Knob back to 'Off' when you have finished.

3.2.4. Oven Thermostat Heat Settings Table

- The following table is provided as an approximate guide.

POSITION	TEMPERATURE
MAX.	280°C
9	240°C
8	230°C
7	220°C
6	200°C
5	190°C
4	180°C
3	170°C
2	150°C
1	140°C

3.2.5. Setting the Minute Minder

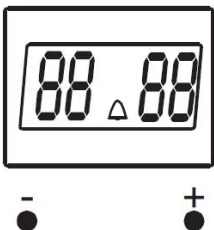
Use of digital minute minder	
	Simultaneously press (+) and (-) buttons of digital minute minder. The display will start flashing, and then you can set the time setting by using (+) and (-) buttons. When you press (+) or (-) buttons after setting the time (Δ) symbol is displayed, and the desiring timer set. At the end of this time period, it will make a beep sound but the oven continues working. In order to turn the oven off, you must take the switch and thermostat of the oven to closed position.

Section 4. Maintenance

Before any maintenance or cleaning work is carried out, **DISCONNECT** the appliance from the **ELECTRICITY** supply and ensure that the appliance is completely cool.

4.1. Cleaning the Oven

Clean spillages from inside the oven as soon as possible after use. Always ensure that the surface has cooled down before cleaning.

Use a cloth with warm soapy water to clean the surface. If the spillage has dried on the surface you may need to use a specialist oven cleaner, available from all good supermarkets.

Clean the glass door with warm soapy water – always ensure the glass is cool before you clean it!

4.2. Changing the Oven Bulb (If fitted to your model)

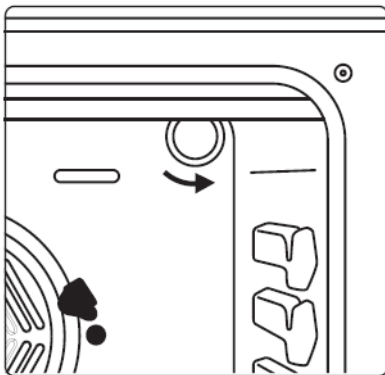

Proceed as follows when the glass is cold:

- Unscrew the glass cover
- Remove the bulb
- Fit new **like for like** bulb (*)
- Replace glass cover

(*) Must be a 25w Type E14 replacement oven bulb available from specialist hardware & lighting shops

4.3. Removing the Oven Door

If your oven is fitted with a removable door, proceed as follows:

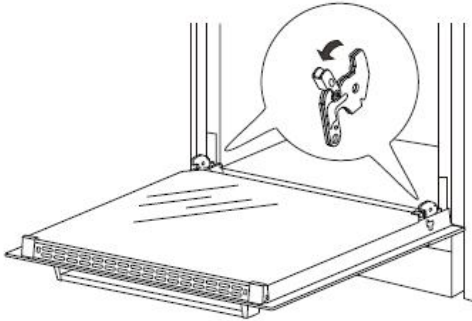

In order to improve access when cleaning the oven, you can remove the door as follows:

Lift the two safety catches up then close the oven door partially. Now lift the door upwards and away from the oven. To refit the door carry out the above in reverse order, ensuring the safety catches are lowered back into place.

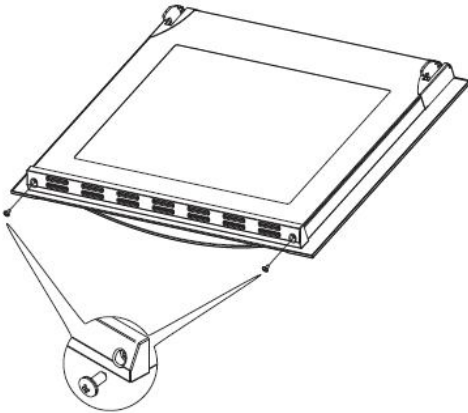

If you need to clean in between the glass door panels, remove the 2 screws and the end panel (as shown left) and then carefully slide the glass out of the door frame. Clean the glass panels and carefully slide the glass back into the door frame. Refit the end panel and ensure that the 2 screws are in place.

N.B. Your guarantee does not cover damaged or broken glass on the oven door.

4.4. Cleaning The Hotplate Burners

N.B The hotplate burners will not operate correctly unless the burner crown and burner cap are maintained in a clean condition and aligned correctly.

Remove the Cap and Crown and clean with soapy water and/or a mild cream cleaner. Clean around the base (burner cup) taking care not to damage the spark electrode (plug).

When the parts are dry, re-assemble ensuring all parts are fully aligned.

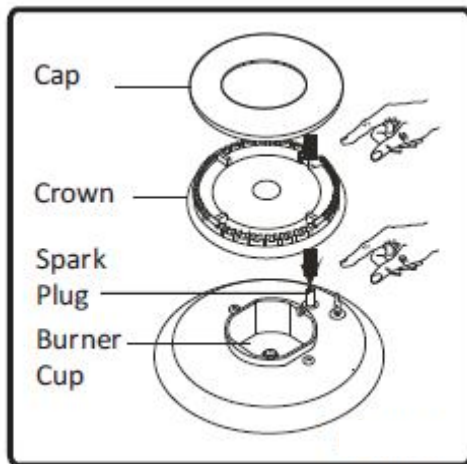

4.5. What to do if something goes wrong

There is no power to the appliance:

- Check there is not a power cut
- Check there is power to the electric socket/appliance

The oven operates but the oven light is not working:

- If your model is fitted with an oven light, replace the oven bulb as described in section 4.2. above. Please note that bulbs are not covered under the guarantee.

YOUR GUARANTEE IS VALID ONLY IN THE UK.

To Register your Appliance simply complete the card in your appliance pack and return it with a stamp affixed or Alternatively you can Register online at www.repairtechuk.com

SERVICE HELP-LINE

Should your appliance develop a fault, please call the Repairtech Service Helpline on:

01527-888133

Please remember to have all your product details available, including the model number, serial number, date of purchase and your retailer's details before registering a fault.

Your service call cannot progress without this information.

DOMESTIC APPLIANCE DISTRIBUTORS;

HENRY JOHN HOUSE
NORTHWAY LANE
ASHCHURCH
TEWKESBURY
GLOUCESTERSHIRE
GL20 8JH

Important Note:

This appliance is marked according to the European directive 2002/96/EC on Waste Electrical and Electronic Equipment (WEEE). By ensuring this product is disposed of correctly, you will help prevent potential negative consequences for the environment and human health, which could otherwise be caused by inappropriate waste handling of this product.

The symbol on the product, or on the documents accompanying the product, the Crossed Out Wheelie Bin, indicates that this appliance may not be treated as household waste. Instead it shall be handed over to the applicable collection point for the recycling of electrical and electronic equipment.

Disposal must be carried out in accordance with local environmental regulations for waste disposal. For more detailed information about treatment, recovery and recycling of this product, please contact your local authority, your household waste disposal service or the retailer where you purchased the product.



We continuously try to improve our products for the benefit of our customers.

For this reason we reserve the right to make changes to any product at any time, without notice

Issue: 01/02-12-2014