

# Montpellier

THE PERFECT BALANCE OF FUNCTION AND STYLE  
LAUNDRY - DISHWASHING - COOKING - COOLING

## Installation and Operating Instructions



## Built in Drawer

WD140BG - Black

WD140ST - Stainless Steel

Please read these instructions carefully before attempting to install or use this appliance.  
We recommend that you keep these instructions in a safe place for future reference.

## Welcome

Thank you for choosing this Montpellier Built in Drawer.

Our Drawer has been designed to provide you with the best combination of style, reliability and performance to give you years of trouble-free use.

You may be familiar with a similar product, but please take time to read these instructions carefully before installing or using your Built in Drawer to ensure you get the most from your purchase.

We recommend that you keep this manual in a safe place for future reference.

Your Built in Drawe is covered by a comprehensive two year Parts & Labour Guarantee. In the unlikely event that you experience a problem with your Drawer, you can rest assured that you are fully protected against the cost of repairs for the first 24 months . Please note that any claim must be accompanied by the model reference number, serial number and proof of purchase.

To activate your guarantee, you will need your product serial number. This can be found on the rear of the machine.

There are two ways to register your Guarantee:

- Online: Visit the Support page on our website and complete the online Product Registration form. [www.montpellier-appliances.com](http://www.montpellier-appliances.com)
- By Post: Simply detach and fill in the form provided, attach a stamp and send it in the post. Don't forget to include your e-mail address so that we can send confirmation through to you.



Note: We are unable to take registrations over the phone.

## DEAR CUSTOMER

---

This appliance must only be used for the purpose for which it is intended, i. e. domestic cooking, defrosting and reheating foods. Any other use could be dangerous and may lead to premature failure of the appliance.

Under no circumstances should any external covers be removed for servicing or maintenance except by suitably qualified personnel.

These instructions have been compiled in order to help you learn how to handle the appliance. So please read them carefully before you use the appliance for the first time in order to avoid possible accidents.

Please keep the instruction manual and store it in a safe place so that it can be consulted at any time.

It is necessary to follow the instructions in the manual carefully in order to avoid possible accidents.

## TABLE OF CONTENTS

---

Safety instructions.....	4
How to save energy.....	5
Unpacking.....	5
Disposal of the appliance.....	5
Installation.....	6
Operation.....	8
Prior first use.....	8
Using your Warming Drawer.....	8
Cleaning and maintenance.....	11
Technical information.....	12

## SAFETY INSTRUCTIONS

---

- Warming drawers become hot during and immediately after use. Ensure you do not touch any of the internal components.
- After use, please ensure that the appliance is switched off.
- Do not rest or sit on the drawer when open as this will damage the telescopic runners.
- The maximum capacity of the drawer is 25 kg.
- Do not cover the bottom of the warming drawer with aluminium foil or other objects.
- Never pour water directly into the warming drawer.
- Do not use this appliance for heating liquids.
- To avoid scratching, do not drag dishes on the bottom of the warming drawer.
- Use suitable containers or crockery.
- Residual condensation could eventually damage the warming drawer and surrounding cabinets. It is advisable to dry any wet parts when the warming drawer is cold.
- Do not store plastic or flammable objects in the warming drawer.
- We recommend the use of oven gloves or adequate protection when removing crockery from the drawer.
- Never insert objects (e.g. screwdrivers, sharp objects, papers etc.) in the heating element and ventilation slots.
- Do not use harsh abrasive cleaners or sharp metal scrapers to clean the door glass as they can scratch the surface which could then result in the glass shattering.

## HOW TO SAVE ENERGY

---



Using energy in a responsible way not only saves money but also helps the environment.

So let's save energy! And this is how you can do it:

- Make sure the door is properly closed. Heat can leak through spillages on the door seals. Clean up any spillages immediately.

## UNPACKING

---

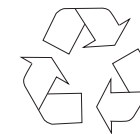

During transportation, protective packaging was used to protect the appliance against any damage.

After unpacking, please dispose of all elements of the packaging in a way that will not cause harm to the environment. All materials used for packaging the appliance are environmentally friendly; they are 100% recyclable and are marked with the appropriate symbol.

### Caution!

During unpacking, the packaging materials (polythene bags, polystyrene pieces etc.) should be kept out of reach of children.

## DISPOSAL OF THE APPLIANCE

---



Old appliances should not simply be disposed of with normal household waste, but should be delivered to a collection and recycling centre for electric and electronic equipment.

A symbol shown on the product, the instruction manual or the packaging shows that it is suitable for recycling.

Materials used inside the appliance are recyclable and are labelled with information concerning this. By recycling materials or other parts from used devices you are making a significant contribution to the protection of our environment.

Information on appropriate disposal centres for used devices can be provided by your local authority.

## INSTALLATION

### ▶ Installing the warming drawer

- The kitchen should be dry and have effective ventilation according to the existing technical provisions.
- Main lead behind the warming drawer must be placed in such manner to avoid touching the back panel of the appliance because of the heat it develops during operation.
- Remove any packaging materials (foils, artificial foam, nails etc.) from the reach of children because they represent potential danger. Children may swallow small parts.

Check the measurements on Fig.3 to confirm the requirements for your installation. Please note, the oven dimensions show a standard oven and will vary depending on the appliance being installed above the warming drawer.

1.Run the mains lead to the switched fused spur outlet to be used and connect to the mains electrical supply. Do not switch on until installation is complete.

2.Locate the product centrally on the supporting shelf and fix into position using the fixing screws supplied.

3.Carefully fit the appliance on top of the warming drawer, taking care not to scratch the top stainless edge of the drawer unit. Ensure that the mains connection lead is located near to the power outlet to avoid having to remove the product again to connect the mains electrical supply.

4.Secure the oven into the housing using appropriate fixing screws.

The casing of this appliance will get hot. Ensure that any cables that may come into contact with the appliance once installed are suitable for use at 85°C.

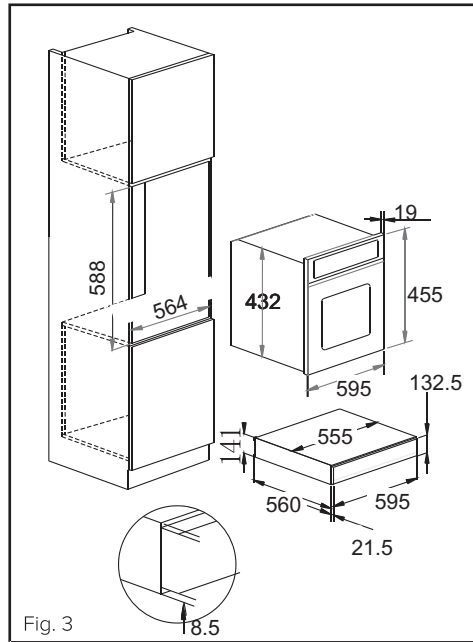

## INSTALLATION

### ▶ Electrical connection

Warning! This appliance must be earthed.

We recommend that the appliance is connected by a qualified electrician who is a member of the N. I. C. E. I. C. and who will comply with the I. E. T. and local regulations.

This appliance is intended to be connected to fixed wiring and is not suitable for connection to a 13A plug or 13A supply.

This appliance is intended to be connected to fixed wiring by a double pole switch, having a contact separation of at least 3mm in all poles. The switch must be positioned no further than 2m from the appliance.

This appliance is supplied with a 3 core mains cable; the wires are in accordance with the following code:

Green and Yellow = Earth  
Blue = Neutral  
Brown = Live

Please note:

- The mains cable must only be replaced by a qualified electrician or service engineer and must be of equivalent or better rating (i. e. 0.5mm<sup>2</sup>, HO3VV-F).
- The current rating of the fuse or circuit breaker protecting this appliance should be marked on the socket outlet (3A).
- Assembly and electrical connection should be carried out by specialised personnel.
- When installing this product, we recommend you seek the help of another individual.

The mains isolation switch must be accessible after installation.

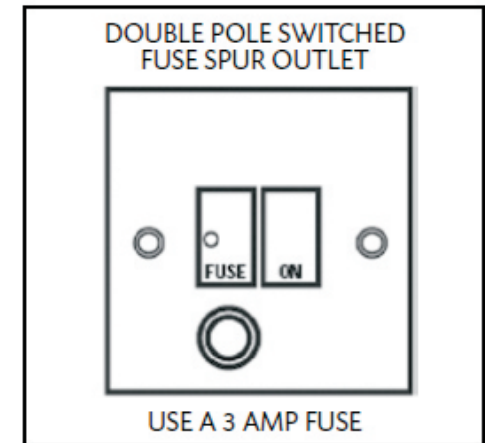

## OPERATION

### ▷ Prior first use

Before using the warming drawer for the first time we recommend that you clean it with a damp cloth, then dry thoroughly.

Preheat the empty drawer at maximum temperature for at least 2 hours.

A slightly unpleasant smell may be produced, caused by grease remaining on the warming drawer elements from the production process.

### Caution!

**When heating the warming drawer for the first time, it is normal phenomenon to give off smoke and peculiar smell. This will disappear about 30 min later.**

### ▷ Using Your Warming Drawer

To open the drawer  
Press the front of the drawer briefly and it will spring open slightly.



Hold the front panel and pull the drawer open.



To close the drawer  
Gently push the drawer back to its closed position.

## OPERATION

### Using the WARMING DRAWER

- Place the dishes in the drawer.
- Set the required temperature.
- Press the power switch which will light up to confirm the warming drawer is switched on.
- Close the drawer gently.
- Switch the appliance off before removing the warmed dishes.

### Selecting the Temperature

- The temperature knob enables a temperature adjustment between approx. 40°C and 80°C.
- Turn the temperature knob to the required position.
- To prevent damage to the thermostat, do not force the temperature knob past the maximum position.
- The symbols do not indicate absolute temperature values but recommendations for optimum settings for cups and dishes.

Knob Position	Approx Temperature	Usage Information
1	Approx. 40°C	To prevent hot drinks from cooling too quickly, use this temperature setting to warm the cups to a temperature that is safe to touch.
2	Approx. 60°C	To prevent hot food from cooling too quickly, use this temperature setting to warm plates or serving dishes. The use of oven gloves or pot holders is recommended for this setting.
3	Approx. 80°C	The thermostat is set to maximum temperature. The use of oven gloves or pot holders is necessary for this setting.

## OPERATION

---

### Warming Times

The time necessary for warming depends on various factors:

- Material and thickness of the dishes.
- Quantity of dishes to be warmed.
- Arrangement of dishes in the drawer.
- Temperature setting.

Therefore, exact warming times cannot be provided.

With use, experience will demonstrate optimal warming times and temperature settings.

### Warming drawer capacity

The capacity of the warming drawer is 16kg.

The number of items this includes depends on the size and thickness of your crockery.

## CLEANING AND MAINTENANCE

---

### IMPORTANT:

- Always disconnect the appliance from the power supply before undertaking any cleaning.
- You should always allow the warming drawer to cool fully after use before undertaking any cleaning.
- Never use high pressure water or steam cleaners.
- Do not use detergents containing soda, acids or chlorides, abrasive detergents (in powder or lotion), abrasive sponges (e.g. steel wool) or sponges containing residuals of abrasive detergents, descaling detergents, dishwasher detergents or oven sprays.

### Warming drawer exterior

- Clean with a damp cloth. If it is very dirty, add a few drops of dish washing detergent to the water. Dry with a dry cloth.
- Do not use corrosive or abrasive detergents as they can create dull areas. If any of these products accidentally come into contact with the warming drawer, clean the appliance immediately with a damp cloth.
- Slight colour differences on the front of the appliance are due to the use of different materials such as glass, plastic and metal.

### Front panel

- Use a mild detergent and a soft window cleaning cloth or a microfibre cloth that does not leave fibres on the surface. Wipe horizontally, without pressing.
- Do not use corrosive products, hard sponges or rough cloths for cleaning. Clean the aluminium surfaces with a dry cloth.

## CLEANING AND MAINTENANCE

---

### Glass base

- The glass drawer base can be lifted out to clean the bottom of the drawer. The base can be washed by hand with hot water and a mild detergent. Dry thoroughly.
- Refit the glass base in the drawer only when completely dry.

### Drawer base

- It is advisable to clean the bottom of the drawer after every use, making sure to allow it to cool. This way, grime will not accumulate and cleaning is easier.
- Use a clean cloth, absorbent paper and washing up detergent or specific products for cleaning the vitroceramic top.
- It is advisable to periodically treat the vitroceramic with the special waxes available on the market.

PLEASE NOTE: Steam cleaners must not be used to clean this appliance.

Do not store flammable materials in the warming drawer .

Do not allow grease or food particles to build up around the door .

### IMPORTANT:

When correctly installed, your product meets all safety requirements laid down for this type of product. However , special care should be taken around the rear or the underneath of the appliance as these areas are not designed or intended to be touched and may contain sharp or rough edges that could cause injury.

### Troubleshooting

If the dishes are not warm enough, make sure:

- the appliance is on.
- the right temperature has been set.
- the heat openings are not covered by large dishes .
- the dishes have been warmed for long enough.

## TECHNICAL INFORMATION

---

Model	WD140BG WD140ST
Voltage rating	220-240V~50Hz
power rating	420W

# Here For You

---

## After-sales assistance

If you continue to experience problems with your Built in Oven, please call the Montpellier customer service helpline on: **01759 487835**.

Please have all your product details available, including the model number, serial number, date of purchase, and your retailer's details before registering a fault.

The service call cannot progress without this information.

## Your 2 year Manufacturer's guarantee

THIS DOES NOT AFFECT YOUR STATUTORY RIGHTS.

Your new Montpellier appliance carries a free guarantee which protects you against the cost of repairs during the first 24 months from date of purchase provided that:

Any claim is accompanied by evidence of the model reference, model serial number and proof of purchase, such as a Sales Receipt, showing that the appliance was purchased within the 24 months prior to the date of claim.

## What is not covered under the Guarantee

- Any appliance not correctly installed and operated in accordance with the manufacturer's instructions.
- Any appliance that is used for anything other than domestic purposes.
- Any defect caused by accident, misuse, unauthorised modification or inexpert repair.
- Cost of Call-out where a fault cannot be found with the appliance.
- Cost of Call-out for work covering routine maintenance, such as, but not exclusively, cleaning of filters or defrosting.
- Cost of Call-out for work required to correct the alignment of doors following door reversal procedures carried out by you.
- Use of the appliance by anyone other than the Householder.
- Use in any commercial environment.
- Consumable items, such as, but not exclusively, fuses in plugs, bulbs and breakable items which require routine replacement.
- Repair costs incurred that have not been authorised by Montpellier and/or carried out by a non-approved Montpellier engineer.

YOUR GUARANTEE IS VALID ONLY IN THE UK& ROI.

To register your appliance simply complete the card in your appliance pack and return it with a stamp affixed or alternatively you can register online at [www.montpellier-appliances.com/support](http://www.montpellier-appliances.com/support)

## SERVICE HELP-LINE

Should your appliance develop a fault, please call the Montpellier customer service helpline on: **01759 487835**.

Please remember to have all your product details available, including the model number, serial number, date of purchase and your retailer's details before registering a fault.

Your service call cannot progress without this information.

---

Here For You

Montpellier Domestic Appliances Ltd.  
Unit 1, Tewkesbury Retail Park, Northway Lane,  
Tewkesbury, Gloucestershire GL20 8JU

[www.montpellier-appliances.com](http://www.montpellier-appliances.com)



The symbol on the product or on its packaging indicates that this product may not be treated as household waste. Instead it shall be handed over to the applicable collection point for the recycling of electrical and electronic equipment. By ensuring this product is disposed of correctly, you will help prevent potential negative consequences for the environment and human health, which could otherwise be caused by inappropriate waste handling of this product. For more detailed information about recycling of this product, please contact your local city office, your household waste disposal service or the shop where you purchased the product.