

Montpellier

THE PERFECT BALANCE OF FUNCTION & STYLE

LAUNDRY DISHWASHING COOKING COOLING

Installation & Operating Instructions



Under-counter Retro Fridge Freezer
MAB2035EC/K/R/PB Cream, Black, Red, Pastel Blue

Please read these instructions carefully before attempting to install or use this appliance.
We recommend that you keep these instructions in a safe place for future reference.

Thank you for choosing this Montpellier appliance.

Our appliances have been designed to provide you with the best combination of style, reliability and performance, to give you years of trouble-free use.

You may be familiar with a similar product, but please take the time to read these instructions carefully before installing or using your appliance to ensure that you get the most from your purchase.

We recommend that you keep this manual in a safe place for future reference.

Your appliance is covered by a comprehensive two year Parts & Labour Guarantee. In the unlikely event that you experience a problem with your appliance, you can rest assured that you are fully protected against the cost of repairs for the first 24 months. Please note that any claim must be accompanied by the model reference number, serial number and proof of purchase.

To activate your guarantee, you will need your product serial number. This can be found inside your appliance.

NB: Please make sure that you keep a copy of your original sales invoice as this will be needed if any service call is required.

There are three ways to register your Guarantee:

Online: Visit the Support page on our website and complete the online Product Registration form.

www.montpellier-appliances.com

By Post: Simply detach and fill in the form provided, attach a stamp and send it in the post. Don't forget to include your e-mail address so that we can send confirmation through to you.

By Phone: Contact our warranty registration department on **0808 1961 388**

Montpellier
montpellier-appliances.com

12
YEAR
GUARANTEE

PARTS & LABOUR

ACROSS ALL OUR MODELS

Thank you for choosing this product.

This User Manual contains important safety information and instructions on the operation and maintenance of your appliance.

Please take the time to read this User Manual before using your appliance and keep for future reference.

The design and specifications are subject to change without prior notice for product development.

This manual is a manual in common use of products within our company. Do not use for any purpose other than described in this user guide.

This appliance is intended to be used in household and domestic applications only.

Important safety instructions

WARNING To reduce the risk of fire, electrical shock, or injury when using your refrigerator, follow these instructions.

Read all instructions before using the refrigerator.

WARNING: This appliance is not intended for use by persons (including children) with reduced physical, sensory or mental capabilities, or lack of experience and knowledge, unless they have been given supervision or instruction concerning use of the appliance by a person responsible for their safety.

Children should be supervised to ensure that they do not play with the appliance.

WARNING: Keep ventilation openings, in the appliance enclosure or in the built-in structure, clear of obstruction.

WARNING: Do not use mechanical devices or other means to accelerate the defrosting process, other than those recommended by the manufacturer.

WARNING: Do not damage the refrigerant circuit.

WARNING: Do not use electrical appliances inside the food storage compartments of the appliance, unless they are of the type recommended by the manufacturer.

Do not store explosive substances such as aerosol cans with a flammable propellant in this appliance.

WARNING: When positioning the appliance, ensure the supply cord is not trapped or damaged.

WARNING: Do not locate multiple portable socket outlets or portable power supplies at the rear of the appliance.

DANGER: Risk of child entrapment.

This appliance can be used by children aged from 8 years and above and persons with reduced physical, sensory or mental capabilities or lack of experience and knowledge if they have been given supervision or instruction concerning use of the appliance in a safe way and understand the hazards involved. Children shall not play with the appliance.

Cleaning and user maintenance shall not be made by children without supervision.

Children should be supervised to ensure that they do not play with the appliance.

Cleaning and user maintenance must not be performed by children without supervision.

Children aged from 3 to 8 years are allowed to load and unload refrigerating appliances.

To avoid the possibility of child entrapment; please take the following precautions before disposing of the refrigerator.

- Remove all doors from the unit
- Leave the shelves in place so that children cannot easily climb inside

This appliance is intended to be used in a household and similar domestic applications only.

This refrigerating appliance is intended to be used at ambient temperatures ranging from 16°C to 38 °C

This refrigerating appliance is not intended to be used as a built-in appliance.

WARNING: This refrigerator should be properly grounded for your safety. The power cord of this refrigerator is equipped with a three-prong plug which is compatible with standard three-prong wall outlets to minimise the possibility of electrical shock.

This refrigerator requires a standard 220-240V/50Hz electrical outlet with three-prong grounded socket. Do not, under any circumstances, cut or remove the third ground prong from the power cord supplied. Improper use of the grounded plug can result in the risk of electrical shock.

This refrigerator is not designed to be used with an inverter.

The cord should be secured behind the refrigerator and not left exposed or dangling, so as to prevent accidental injury.

Never unplug the refrigerator by pulling the power cord. Always grip the plug firmly and pull straight out from the socket.

Do not use an extension cable with this appliance. If the power cord is too short, have a qualified electrician or service technician install an outlet near the appliance. Use of an extension cord can negatively affect the performance of the unit.

WARNING: If the supply cord is damaged, it must be replaced by the manufacturer, its service agent or similarly qualified persons in order to avoid a hazard.

CAUTION: All package of the refrigerator must be removed before application.

A single tri-pin plug must be earthed with a 13A fuse.

No earthing through pipes, telephone wires or gas pipes.

Using improper voltage may result in damage to the appliance and possible injury to the user. Correct voltage is listed on the rating label.

To avoid damage to the vital parts, wait at least 5 minutes before replugging after a power cut.

No toxic, inflammable, explosive or caustic objects (propane lighter gas, glue, petroleum, alcohol and so on), should be placed near the appliance.

Keep the refrigerator body away from water and don't put containers with water on the top cover to avoid electric shock or fire.

Shut off the valve immediately and open the windows for ventilation in case of gas release.

The refrigerator plug must not be touched to avoid an explosion.

To avoid the refrigerator falling down or other accidents, please don't pull the refrigerator door violently, or let kids hang on the door or play inside.

The appliance is not intended for use by young children without supervision.

Power cut: Open the door as little as possible. Don't put any food into the refrigerator until running.

When the appliance is turned off for a long period of time: Refrigerators should be used constantly to avoid affecting the service life, the refrigerator should be kept on operating even if there's no food preserved. Unplug the refrigerator when out of work for quite a long time, so as to avoid electric shock or fire caused by insulation ageing.

Dry the inside with tablecloth. Dispose the refrigerator in a ventilate place after air-drying.

Please move the plug away from the socket if you do not use it for quite a long time.

Do not place bottles in the freezer, to avoid cracking from being frozen.

Be careful when moving the refrigerator.

Please refer to the related instructions in the book.

Hold the plug instead of the wire when removing the plug.

Do not touch switches or plugs on the refrigerator with wet hands.

Name of accessories

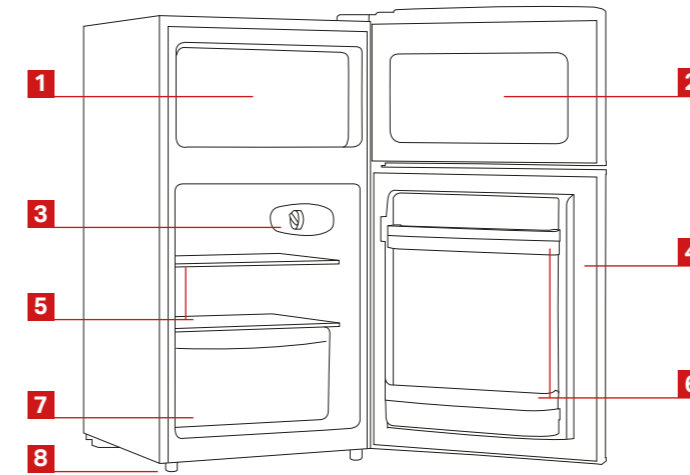

- 1 Freezer
- 2 Freezer Door
- 3 Thermostat & light
- 4 Fridge Door
- 5 Glass Shelves
- 6 Door Balconies
- 7 Salad Crisper
- 8 Adjustable Feet

The accessories vary from type to type. Please refer to the packing list for details.

Before Application

Preparations

- Unwrap all the package accessories, including the pedestal, plastic stuffing and some adhesive tapes.
- Check accessories and documents detailed on the loading sheet.
- Place the refrigerator properly (Refer to this manual content).
- Clean the inside of the refrigerator (Refer to this manual content).
- Make sure the appliance is allowed to stand for a minimum of 4 hours before turning on.
- Open the doors and wait till the temperature inside and out of the refrigerator becomes the same.

Trial

The refrigerator is about to work once you plug in and turn the thermostat knob to any setting in the range of 1 to 7. Both sides of the refrigerator will become warm when the door is closed for several minutes. It shows the refrigeration works well.

Notice: Do not open the doors before the appliance is down to temperature (approximately 2 hours in winter or 5 hours in summer).

There may be some noise during the refrigeration, which will diminish when refrigeration ends.

About the thermostat

Thermostat knob can adjust the temperatures in the refrigerator. There are severing settings marked 1-7 respectively, which means refrigeration instead of specific temperatures. "0" stands for "Stop", "7", may lead to a consecutive operation occasionally.

The smaller number, the higher the temperature in the refrigerator, vice versa.

Consumers can adjust the thermostat knob according to their specific needs. The knob should be switched to the middle setting in everyday life.

CAUTION: The '7' setting is applicable to quick freeze or preserve large amount of food. Switch to the usual setting after quick freezing to avoid spoiling the food.

Before Application

About Preservation

To avoid odours or dehydration, wrap the food with plastic film or seal the food in containers and lay them evenly on the shelves.

Put the fruits and vegetables into the vegetable crisper to keep them fresh.

Don't put hot food into the refrigerator until it becomes room temperature.

Don't put the food in glass or sealed containers into the freezer otherwise the glass container may crack when frozen.

To avoid cold air leak, don't open the door too often or for too long. Keep some room around food, as this is good for food preservation.

Thawed food can't be refrozen; it must be eaten as soon as possible.

It's better to wash and dry groceries before preservation.

Food kept too long in the refrigerator will loose its taste and freshness. Spoiled and smelly food must not be kept in the appliance.

Divide the food into proper pieces for freezing and thawing according to your need.

Regularly clean surfaces that can come in contact with food and accessible drainage systems.

Store raw meat and fish in suitable containers in the refrigerator, so that it is not in contact with or dripping onto other food.

If the refrigerating appliance is left empty for long periods, switch off, defrost, clean, dry, and leave the door open to prevent mould developing within the appliance.

Application

Set the temperature range and store food according to the instructions, otherwise the food may deteriorate quickly.

Refrigerator

The temperature in the refrigerator is between 0°C-10°C, which is applicable to preserve food, such as vegetables and fruits, for a short period.

Optimise the preservation and make full use of the space by sorting the food.

Freezer

The temperature is less than -18°C in the freezer, which is applicable to preserve food needing to be kept for a long period, such as meat and fish. Glass items contained liquid cannot be kept in the freezer.

CAUTION: Keep the following things out of the freezer-carbonating beverage and instant cold pack in the market (such as ammonium-nitrate and carbamide).

Ice-making

Drop cold boiled water or beverage into cleaned ice tray until it reaches 80 per of the tray. Then put the tray into the freezer.

Bend the tray a little, avoid damaging the ice tray with too much force.

Maintenance

About Cleaning

Clean the refrigerator every month.

Unplug the refrigerator first (The refrigerator mustn't be plugged within five minutes once being unplugged so as to avoid malfunctions).

Then wipe the refrigerator with a towel soaked in warm water or dilute neutral detergent and dry it.

CAUTION: The following products are forbidden to cleanse the refrigerator such as (faint) alkali detergent, bur powder, boiled petroleum, alcohol, benzene, caustic detergent, nylon brush and banana oil, so as not to damage the plastic surface.

Cleanse any cooking oil or soy sauce spots instantly so as not to spoil the plastic parts.

Once the door gasket gets stained, wipe them off as son as possible to avoid the malfunctions such as inefficient seal or leaking of cold air.

Check the plug after cleaning

Are the wire and plug damaged?

Has the refrigerator been plugged in?

About Defrosting

When there's a layer of frost on the surface of the freezer;

Unplug the refrigerator and take the food to a cool place, making sure that it is well wrapped and insulated.

Once the ice has defrosted wipe up the water with a dry cloth.

Plug in the refrigerator and begin to refrigerate.

WARNING: Do not use mechanical devices or other means to accelerate the defrosting process, other than those recommended by the manufacturer.

Applications and disassembly of the accessories

Vegetable Crisper

Vegetable Crisper is applicable for preserving fruits and groceries.

Dissemble it by pulling outward.

Door Balconies

Door balconies are applicable for storing beverages and bottled food stuffs.

Dissemble them by lifting upward.

Drain Hole

When the drain channel has standing water, use the supplied accessory to clear any debris from the drain hole.

Keep the water outlet clear at all times.

About placement

Keep well ventilated.

Keep away from insulation or heat.

Keep away from moist places with water, so as to avoid electricity malfunctions.

Keep some room around the refrigerator. Keep at least 10cm between the wall and each side of the refrigerator.

Keep away from caustic and toxic gas.

The appliance must be positioned so that the plug is accessible.

Avoid lengthening or twisting the wire at will or putting the wire close to the compressor on the back of the refrigerator.

Avoid putting the refrigerator or other heavy objects on the wire, so as not to cause danger by damaging the wire.

WARNING: If the supply cord is damaged, it must be replaced by the manufacturer, its service agent or similarly qualified persons in order to avoid a hazard.

CAUTION:**Replacing the lamp**

Lamp can not be replaced by user, if the lamp is damaged, it must be replaced by manufacturer, its service agent or similarly qualified persons in order to avoid a hazard.

Conveyance

Take the food out of the refrigerator and empty the ice from the ice tray.

Remove the compressor baffle on the back of the refrigerator, take out the water tray on the top of the compressor and empty the water.

It's forbidden to grasp the door, the top or the valves while moving the refrigerator.

Violent installing and dismantling, over-slanting, insulation, snow or rain are forbidden during convey to avoid malfunctions.

The slant-angle should be kept less than 45 degrees.

There should be more than two people to convey.

Self-check before repairing**The refrigerator does not work**

Is the plug correctly fitted in the socket?

Does the power source work well?

Does the thermostat knob point at the 'stop' setting?

Whether the refrigerator replugged in less than five minutes?

Food is frozen in the refrigerator

Whether the thermostat setting too high?

Does the food preserved touch the refrigeration source on the back? Whether the food preserved too watery?

Compressor works consecutively?

Is the door closed absolutely?

Is there a heat source near the refrigerator'?

Are the foods too close to each other for the cold air to circulate?

Is there any hot food in the refrigerator?

Temperature of preserved food not ideal

Are there too many foods preserved?

Is the door not closed absolutely or opened frequently?

Is the thermostat set to a setting too low?

Annoying noise

Has the package been removed?

Is the refrigerator laid evenly?

Is the refrigerator placed against the wall?

Are the adjustable front-legs loose?

Get numb when touch the refrigerator

Does the grounding work well?

If you still feel numb while the refrigerator grounded, please unplug instantly and cont post-service Dep.

The refrigerator dissipates heat all over

On both sides of the refrigerator are expansion valves, which dissipates heat during refrigeration.

No need to worry about it.

CAUTION: If the refrigerator is abnormal after these checks, please contact Post-service Dep. Or local authorised maintenance department.

Model	MAB2035EC, MAB2035EK, MAB2035ER, MAB2035EPB
Climate Type	N/ST
Electrical Shock Protect Mode	1
Total Volume (L)	84
Fresh Food Volume (L)	59
Frozen Food Volume (L)	25
Freezing Capacity (Kg/24h)	2.0
Overall Dimensions (mm) (width, depth, height)	455, 520, 855
Rated Voltage	220 - 240
Rated Frequency (Hz)	50
Rated Current (A)	1.0
Rated Power (W)	100
Refridgerant	R600a
Refridgerant Weight (g)	36
Annual Energy Consumption (k Wh/a)	166
Temperature Rise Time (h)	7.5
Vesicant	Cyclopentane
Noise dB (A)	39
Net Weight (kg)	19

NOTICE: The technique indexes in the form are tested under a standard situation. If there is any alteration, please refer to the nameplate of the refridgerator.

Model	MAB2035EC, MAB2035EK, MAB2035ER, MAB2035EPB
Salad Crisper	1
Shelf	2
Ice Tray	1
Door Balconies	2
Instructions	1

Circuit Diagram

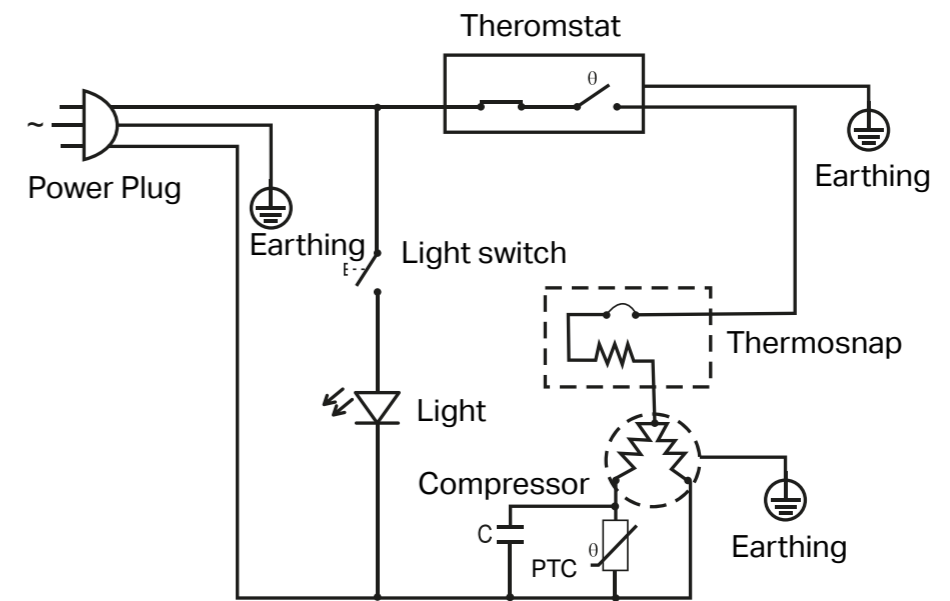

After-sales assistance

If you continue to experience problems with your appliance, please call the Montpellier customer service helpline on: **01759 487839**

Please have all your product details available, including the model number, serial number, original sales invoice (clearly showing model number, date of purchase and your retailer's details) before registering a fault.

The service call cannot progress without this information.

Your 2 year Manufacturer's guarantee

THIS DOES NOT AFFECT YOUR STATUTORY RIGHTS.

Your new Montpellier appliance carries a free guarantee which protects you against the cost of repairs during the first 24 months from date of purchase provided that:

Any claim is accompanied by evidence of the model reference, model serial number and proof of purchase, such as a Sales Receipt, showing that the appliance was purchased within the 24 months prior to the date of claim.

What is not covered under the Guarantee

- Any appliance not correctly installed and operated in accordance with the manufacturer's instructions
- Any appliance that is used for anything other than domestic purposes.
- Any defect caused by accident, misuse, unauthorised modification or inexpert repair.
- Cost of Call-out where a fault cannot be found with the appliance. Cost of Call-out for work covering routine maintenance, such as, but not exclusively, cleaning of filters or defrosting.
- Cost of Call-out for work required to correct the alignment of doors following door reversal procedures carried out by you. Use of the appliance by anyone other than the Householder. Use in any commercial environment.
- Consumable items, such as, but not exclusively, fuses in plugs, bulbs and breakable items which require routine replacement. Repair costs incurred that have not been authorised by Montpellier service and/or carried out by an non-approved Montpellier engineer.

- Montpellier Appliances do not accept claims for consequential loss, rusting, corroding, delivery damage or scratches.

YOUR GUARANTEE IS VALID ONLY IN THE UK & THE REPUBLIC OF IRELAND

To register your appliance simply complete the card in your appliance pack and return it with a stamp affixed or alternatively you can register online at:

montpellier-appliances.com/support

...or by phone, call our warranty registration department on **0808 1961 388**

SERVICE HELP-LINE

Should your appliance develop a fault, please call the Montpellier customer service helpline on:

01759 487 839

Please remember to have all your product details available, including the model number, serial number, date of purchase and your retailer's details before registering a fault.

Montpellier Domestic Appliances Ltd.

Unit 1, Tewkesbury Retail Park, Northway Lane,
Tewkesbury, Gloucestershire GL20 8JU

www.montpellier-appliances.com



The symbol on the product or on its packaging indicates that this product may not be treated as household waste. Instead it shall be handed over to the applicable collection point for the recycling of electrical and electronic equipment. By ensuring this product is disposed of correctly, you will help prevent potential negative consequences for the environment and human health, which could otherwise be caused by inappropriate waste handling of this product. For more detailed information about recycling of this product, please contact your local city office, your household waste disposal service or the shop where you purchased the product.