

Montpellier

THE PERFECT BALANCE OF FUNCTION AND STYLE
LAUNDRY - DISHWASHING - COOKING - COOLING

Installation and Operating Instructions



99/142/198Ltr Chest Freezer

MCF100/140/200EW - White

Please read these instructions carefully before attempting to install or use this appliance.
We recommend that you keep these instructions in a safe place for future reference.

Welcome

Thank you for choosing this Montpellier appliance.

Our appliances have been designed to provide you with the best combination of style, reliability and performance to give you years of trouble-free use.

You may be familiar with a similar product, but please take time to read these instructions carefully before installing or using your appliance to ensure you get the most from your purchase.



2
YEAR
GUARANTEE
— PARTS & LABOUR —
ACROSS ALL OUR MODELS
Montpellier
www.montpellier-appliances.com

We recommend that you keep this manual in a safe place for future reference.

Your appliance is covered by a comprehensive two year Parts & Labour Guarantee. In the unlikely event that you experience a problem with your appliance, you can rest assured that you are fully protected against the cost of repairs for the first 24 months. Please note that any claim must be accompanied by the model reference number, serial number and proof of purchase.

To activate your guarantee, you will need your product serial number. This can be found inside your appliance.

NB: Please make sure that you keep a copy of your original sales invoice as this will be needed if any service call is required.

There are three ways to register your Guarantee:

- **Online:** Visit the Support page on our website and complete the online Product Registration form. www.montpellier-appliances.com
- **By Post:** Simply detach and fill in the form provided, attach a stamp and send it in the post. Don't forget to include your e-mail address so that we can send confirmation through to you.
- **By Phone:** Contact our warranty registration department on **0808 1961388**

Thank you for choosing this product.

This User Manual contains important safety information and instructions on the operation and maintenance of your appliance.

Please take the time to read this User Manual before using your appliance and keep this book for future reference.

The design and specifications are subject to change without prior notice for product improvement.

CONTENTS

1 Safety warnings

1.1 Warning	1-2
1.2 Meaning of safety warning symbols	3
1.3 Electricity related warnings	3
1.4 Related warnings for use	4
1.5 Warnings related to placing items	5
1.6 Warnings for energy	5
1.7 Warnings related to disposal	5

2 Proper use of freezer

2.1 Names of components	6
2.2 Temperature Control	7-8
2.3 Placement	9
2.4 Changing the Light (optional)	9
2.5 Start to use	9
2.6 Energy saving tips	9

3 Maintenance of freezer

3.1 Cleaning	10
3.2 Defrost	10
3.3 Stop using	10

4 Trouble shooting	11
--------------------	----

DEAR CUSTOMER:

Thank you for buying this freezer. To ensure that you get the best results from your new freezer, please take time to read through the simple instructions in this booklet. Please ensure that the packing material is disposed of in accordance with the current environmental requirements.

When disposing of any freezer equipment please contact your local waste disposal department for advice on safe disposal. This appliance must be only used for its intended purpose.

1 Safety warnings

1.1 Warning



Warning: risk of fire / flammable materials

THIS appliance is intended to be used in household and domestic applications only.

THIS appliance should be left to stand for a minimum of 4 hours before turning on for the first time, or after being moved.

THIS appliance is not intended for use by persons (including children) with reduced physical, sensory or mental capabilities, or lack of experience and knowledge, unless they have been given supervision or instruction concerning use of the appliance by a person responsible for their safety.

CHILDREN should be supervised to ensure that they do not play with the appliance.

IF the supply cord is damaged, it must be replaced by the manufacturer, its service agent or similarly qualified persons in order to avoid a hazard.

DO not store explosive substances such as aerosol cans with a flammable propellant in this appliance.

THE appliance has to be unplugged after use and before carrying out user maintenance on the appliance.

WARNING: Keep ventilation openings, in the appliance enclosure or in the built-in structure, clear of obstruction.

WARNING: Do not use mechanical devices or other means to accelerate the defrosting process, other than those recommended by the manufacturer.

WARNING: Do not damage the refrigerant circuit.

WARNING: Do not use electrical appliances inside the food storage compartments of the appliance, unless they are of the type recommended by the manufacturer.

WARNING: Please abandon the refrigerator according to local regulators for its use flammable blowing gas and refrigerant.

WARNING: When positioning the appliance, ensure the supply cord is not trapped or damaged.

WARNING: Do not locate multiple portable socket-outlets or portable power supplies at the rear of the appliance.

DO not use extension cords or ungrounded 2 prong adapters.

DANGER Risk of child entrapment. Before you throw away your old refrigerator or freezer:

–Take off the doors .

Leave the basket in place so that children may not easily climb inside

REFRIGERANT and cyclopentane foaming material used for the appliance are flammable. Therefore, when the appliance is scrapped, it shall be kept away from any fire source and be recovered by a special recovering company with corresponding qualification other than be disposed by combustion, so as to prevent damage to the environment or any other harm.

THE necessity that, for doors or lids fitted with locks and keys, the keys be kept out of the reach of children and not in the vicinity of the refrigerating appliance, in order to prevent children from being locked inside.

FOR EU standard: This appliance can be used by children aged from 8 years and above and persons with reduce physical sensory or mental capabilities or lack of experience and knowledge if they have been given supervision or instruction concerning use of the appliance in a safe way and understand the hazards involved. Children shall not play with the appliance. Cleaning and user maintenance shall not be made by children without supervision. Children aged from 3 to 8 years are allowed to load and unload refrigerating appliances.

TO avoid contamination of food, please respect the following instructions:

- Opening the door for long periods can cause a significant increase of the temperature in the compartments of the appliance.
- Clean regularly surfaces that can come in contact with food and accessible drainage systems.
- Clean water tanks if they have not been used for 48 h; flush the water system connected to a water supply if water has not been drawn for 5 days. (note 1)
- Store raw meat and fish in suitable containers in the refrigerator, so that it is not in contact with or drip onto other food.
- Two-star frozen-food compartments are suitable for storing pre-frozen food, storing or making ice-cream and making ice cubes. (note 2)
- One-, two- and three-star compartments are not suitable for the freezing of fresh food. (note 3)
- For appliances without a 4-star compartment: this refrigerating appliance is not suitable for freezing foodstuffs. (note 4)
- If the refrigerating appliance is left empty for long periods, switch off, defrost, clean, dry, and leave the door open to prevent mould developing within the appliance.

Note 1,2,3,4: Please confirm whether it is applicable according to your product compartment type.



FOR a freestanding appliance: this refrigerating appliance is not intended to be used as a built-in appliance.

ANY replacement or maintenance of the LED lamps is intended to be made by the manufacturer, its service agent or similar qualified person. (See chapter 2.4 for lamp replacement)

WARNING: To avoid a hazard due to instability of the appliance, it must be fixed in accordance with the instructions.

TO Prevent A Child From Being Entrapped, Keep Out Of Reach Of Children And Make Sure They Are Not In The Vicinity Of The Freezer.

1.2 Meaning of safety warning symbols

	The symbols indicate prohibited matters, and those behaviors are forbidden. Non-compliance with the instructions may result in product damages or endanger the personal safety of users.
Prohibition symbols	
	The symbols indicate matters that must be followed, and those behaviors must be strictly executed in line with the operation requirements. Non-compliance with the instructions may result in product damages or endanger the personal safety of users.
Warning symbols	
	The symbols indicate matters to pay attention to, and these behaviors shall be specially noted. Due precautions are needed or minor or moderate injuries or damages of the product will be caused.
Note symbols	

This manual contains lots of important safety information which shall be observed by the users.

1.3 Electricity related warnings

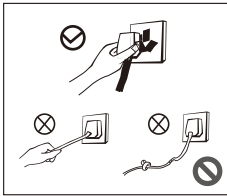

- Do not pull the power cord when pulling the power plug of the freezer. Please firmly grasp the plug and pull it out from the socket directly.
- Do not damage the power cord under any condition so as to ensure safety use, do not use when the power cord is damaged or the plug is worn.
- Worn or damaged power cord shall be replaced in manufacturer-authorized maintenance stations.

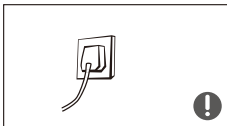

- The power plug should be firmly contacted with the socket or else fires might be caused. Please ensure that the grounding electrode of the power socket is equipped with a reliable grounding line.



- Please turn off the valve of the leaking gas and then open the doors and windows in case of leakage of gas and other flammable gases. Do not unplug the freezer and other electrical appliances considering that spark may cause a fire.

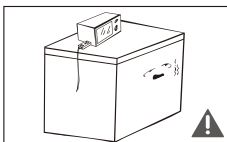

- To ensure safety, it is not recommended that to place regulators, rice cookers, microwave ovens and other appliances on the top of the freezer, those recommended by the manufacturer are not included. Do not use electrical appliances in the food pan.

1.4 Related warnings for use

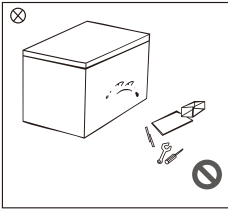

- Do not arbitrarily disassemble or reconstruct the freezer, nor damage the refrigerant circuit; maintenance of the appliance must be conducted by a specialist.
- Damaged power cord must be replaced by the manufacturer, its maintenance department or related professionals in order to avoid danger.

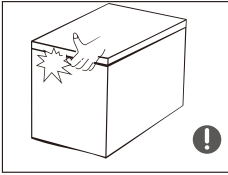

- The gaps between freezer doors and between doors and freezer body are small, be noted not to put your hand in these areas to prevent from squeezing the finger. Please be gentle when open the freezer door to avoid falling articles.
- Do not pick foods or containers with wet hands in the freezing chamber when the freezer is running, especially metal containers in order to avoid frostbite.

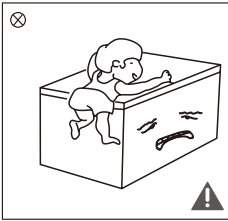

- Do not allow children to enter or climb the freezer to prevent that children are sealed in the freezer or children are injured by the falling freezer.
- Do not spray or rinse the freezer with water, or place it in a damp, splash-prone position, and do not fill it with water. To avoid affecting the electrical insulation performance of the freezer, which in serious cases may lead to accidents such as electric shock and fire.

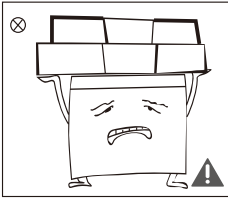

- Do not place heavy objects on the top of the freezer considering that objects may fall when open the door, and accidental injuries might be caused.

1.5 Warnings related to placing items

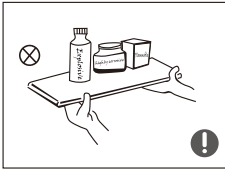

- Do not put flammable, explosive, volatile and highly corrosive items in the freezer to prevent damages to the product or fire accidents.
- Do not place flammable items near the freezer to avoid fires.

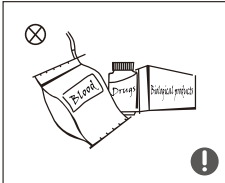

- This product is household freezer and shall be only suitable for the storage of foods. According to national standards, household freezer shall not be used for other purposes, such as storage of blood, drugs or biological products.

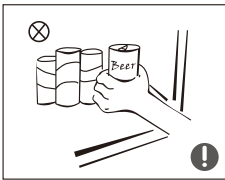

- Do not place items such as bottled or sealed container of fluid such as bottled beers and beverages in the freezer to prevent bursts and other losses.

1.6 Warnings for energy

- 1)Freezer might not operate consistently when sited for an extended period of time below the cold end of the range of temperatures for which the freezer appliance is designed.
- 2)The fact that effervescent drinks should not be stored in food freezer compartments or cabinets or in low-temperature compartments or cabinets, and that some products such as water ices should not be consumed too cold;
- 3)The need to not exceed the storage time recommended by the food manufacturers for any kind of food and particularly for commercially quick-frozen food in food-freezer and frozen-food storage compartments or cabinets;
- 4)The precautions necessary to prevent an undue rise in the temperature of the frozen food while defrosting the refrigerating appliance, such as wrapping the frozen food in several layers of newspaper.
- 5)The fact that a rise in temperature of the frozen food during manual defrosting, maintenance or cleaning could shorten the storage life.
- 6)The necessity that, for doors or lids fitted with locks and keys, the keys be kept out of the reach of children and not in the vicinity of the freezer appliance, in order to prevent children from being locked inside.

1.7 Warnings related to disposal



The freezer's refrigerant and cyclopentane foam materials are combustible materials and discarded freezers should be isolated from fire sources and can not be burned. Please transfer the freezer to qualified professional recycling companies for processing to avoid damages to the environment or other hazards.



Please remove the door of the freezer and shelves which shall be properly placed to avoid accidents of children entering and playing in the freezer.



Correct Disposal of this product

This marking indicates that this product should not be disposed with other household wastes. To prevent possible harm to the environment or human health from uncontrolled waste disposal, recycle it responsibly to promote the sustainable reuse of material resources. To return your used device, please use the return and collection systems or contact the retailer where the product was purchased. They can take this product for environmental safe recycling.

2 Proper use of freezer

2.1 Names of components

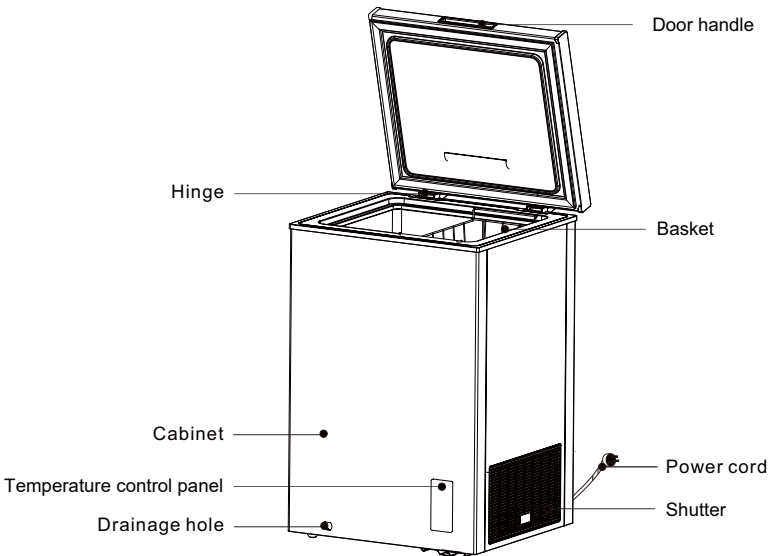

(The picture above is only for reference. The actual configuration will depend on the physical product or statement by the distributor)

- The low temperature of freezer may keep food fresh for a long time and it is mainly used to store frozen foods and making ice.
- The freezer is suitable for storage of meat, fish, shrimp, pastries class and other foods not to be consumed in short term.
- It is not suitable to store bottled or closed containers of fluid items for a long time, if you want to store bottled or closed containers of fluid items, the stored items should not be close to the wall of the freezer.
- There is a certain deviation between the temperature inside the box and the actual setting temperature, which does not affect normal use.
- Please be noted food shall be consumed within the shelf time.
- The fast-freezing function is designed to maintain the nutritional of the food . It can quickly freeze the food in a short time. If a large amount of food need to be frozen at one time, it is recommended that users turn on the fast-freezing function 5 hours in advance. In this case, freezing speed of the freezer increases, it can quickly freeze food and effectively keep the food nutrition.

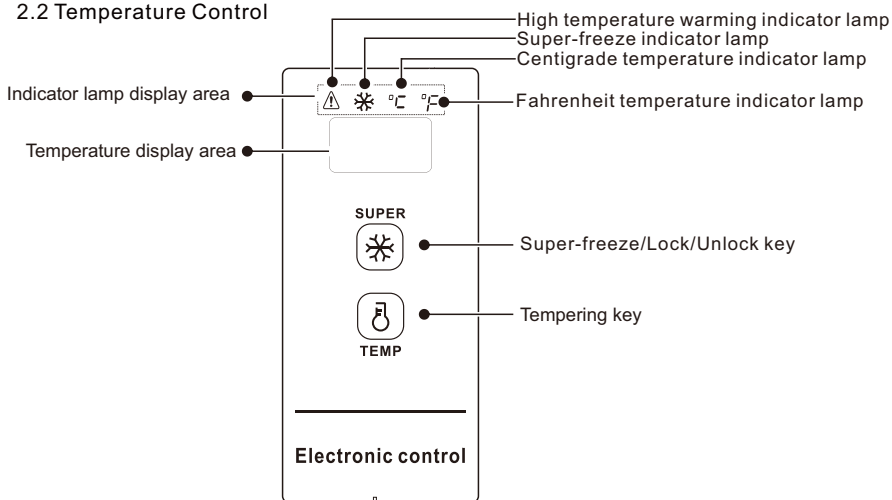

2.2 Temperature Control





(The picture above is only for reference. The actual configuration will depend on the product or statement by the distributor)

► Display control

- When power on the freezer, the display window will be on for 3s, and then it will enter normal operation display, the original electrified display shall be under 18°C;
- Display of normal operation: ① if there is no failure, the set temperature or function mode will be displayed; ② if there is any failure, the failure code will be displayed;
- Show sleep function: the sleep function will open by default after electrifying, after the temperature is confirmed, the display will extinguish after another 30s. The sleep mode could be switched via combined key:



By pressing the key “” and “” for 5s simultaneously, when “ ON ” is displayed in the temperature display area once, it indicates the sleep function is opened.

By pressing the key “” and “” for 5s simultaneously, when “ OF ” is displayed in the temperature display area once, it indicates the sleep function is closed.

Operation control: Open the sleep function. After temperature confirmation for tempering every time, the display area will extinguish for another 30s;
Close the sleep function. After temperature confirmation for tempering every time, the display area will not extinguish and keep on.

► Lock and unlock

After the initial electrification, the key is in lock state by default; it is required to operate after unlocking.

- Lock: after pressing the key “” for continuously 3s, the display area will blink once, and the set temperature will take effect immediately, once entering lock state, the display area will not blink; after no-key operation for 30s, it could also enter automatic lock state, and the display area will blink once.
- Unlock: after pressing the key “” for continuously 3s, the display area will blink once to unlock. Under the lock state, it is required to conduct key operation after unlock.

The various following key operations shall be implemented under unlock state

► Fahrenheit and centigrade temperature conversion

By long pressing key “” for 3s, Fahrenheit and centigrade temperature conversion

could be implemented. When the centigrade temperature is displayed, the centigrade temperature indicator lamp on; and when the Fahrenheit temperature is display, the Fahrenheit temperature indicator lamp in the display area will be on.

► Temperature setting (For settings of -30°C/-22°F, an ambient temperature of 25°C/77°F or less is recommended)

By pressing the key “” , the display window will display the refrigerator temperature,

by pressing the key “” once every time, the refrigerator temperature will change 1 degree Celsius/Fahrenheit;

The specific temperature change is cycled according to the figure below:

Centigrade temperature setting scope:

→10°C→9°C→8°C→……→1°C→0°C→-1°C→……→-28°C→-29°C→-30°C

Fahrenheit temperature setting scope:

→50°F→49°F→48°F→……→33°F→32°F→31°F→……→-20°F→-21°F→-22°F

► Super-freeze function

Enter super-freeze:

① By pressing the key “” , the super-freeze indicator lamp “” will be on;

When setting the centigrade temperature, “-30” will be displayed in the temperature display area, if the compressor continuous operates, the centigrade temperature indicator lamp “°C” will be on.

When setting the Fahrenheit temperature, “-22” will be displayed in the temperature display area, if the compressor continuous operates, the Fahrenheit temperature indicator lamp “°F” will be on.

Quit super-freeze:

① Power on after power failure;

② Continuous operation of compressor for 24 hours;

③ If sensor failure occurs under super-freeze mode, you can quit super-freeze;

④ Under super-freeze mode, you can quit the super-freeze mode by repressing the key “” .

► High temperature alarm

The indicator lamp “” will be on for high temperature alarm.

► Power failure memory

During power failure, the sudden operating state of power failure will be locked, after power is recovered, the operation shall be continued according to the setting before the power failure. The super-freeze function will be quitted after power failure.

► Failure code

If the failure happens, the display area will show corresponding error codes as shown as below table, the user shall contact a specialist for maintenance, so as to make sure the normal use of freezer.

Fault code	E2
Description	Temperature sensor failure

2.3 Placement

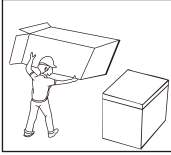

- Before using the freezer, remove all packaging materials including bottom cushions and foam pads and tapes inside the freezer, tear off the protective film on the door and the freezer body.

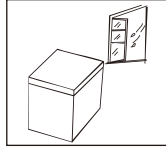

- The freezer should be placed in a well-ventilated indoor place; the ground shall be flat, and sturdy .

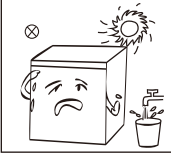

- Keep away from heat and avoid direct sunlight. Do not place the freezer in moist or watery places to prevent rust or reduction of insulating effect.

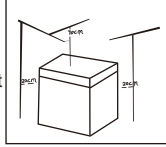

- The top space of the freezer shall be greater than 70cm, and the distances from both sides and backside shall be more than 20cm to facilitate heat dissipation.

2.4 Changing the Light (optional)

Any replacement or maintenance of the LED lamps is intended to be made by the manufacturer, its service agent or similar qualified person.

(Above is only for reference. The actual configuration will depend on the physical product or statement by the distributor)

2.5 Start to use

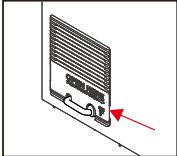

- Use a tool (flat screwdriver or cone), insert it into the gap at the arrow position in the picture and gently pry it open to the outside so as to open the flap.

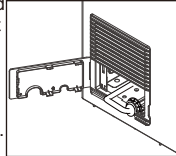

- After opening the picture as shown below, remove the power cord from the hole.

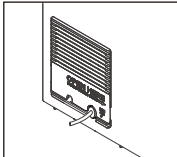

- After the power cord is removed, the cover will then be covered in the opposite direction of the original opening.

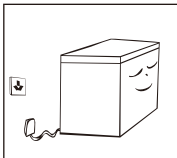

- After transportation, please let the freezer stand for a minimum of 4 hours before turning on the power, otherwise it will lead to a decrease in cooling capacity or a damage to the freezer.
- The freezer shall run 2 to 3 hours before loading fresh or frozen foods; the freezer shall run for more than 4 hours in summer in advance considering that the ambient temperature is high.
- Please pull out the plug in case of power failure or cleaning. Do not connect the freezer to power supply within five minutes to prevent damages to the compressor due to successive starts.

(Above is only for reference. The actual configuration will depend on the physical product or statement by the distributor)

2.6 Energy saving tips

- The appliance should be located in the coolest area of the room, away from heat producing appliances or heating ducts, and out of the direct sunlight.
- Let hot foods cool to room temperature before placing in the appliance. Overloading the appliance forces the compressor to run longer. Foods that freeze too slowly may lose quality, or spoil.
- Be sure to wrap foods properly, and wipe containers dry before placing them in the appliance. This cuts down on frost build-up inside the appliance.
- Appliance storage bin should not be lined with aluminum foil, wax paper, or paper toweling. Liners interfere with cold air circulation, making the appliance less efficient.
- Organize and label food to reduce door openings and extended searches. Remove as many items as needed at one time, and close the door as soon as possible.

3 Maintenance of freezer

3.1 Cleaning

- Dusts behind the freezer and on the ground shall be timely cleaned to improve the cooling effect and energy saving.
- Check the door gasket regularly to make sure there are no debris. Clean the door gasket with a soft cloth dampened with soapy water or diluted detergent.
- The interior of the freezer should be cleaned regularly to avoid odor.
- Please turn off the power before cleaning, remove all food, basket, container, etc.
- Use a soft cloth or sponge to clean the inside of the freezer, with two tablespoons of baking soda and a quart of warm water. Then rinse with water and wipe clean. After cleaning, open the door and let it dry naturally before turning on the power.
- For areas that are difficult to clean in the freezer (such as gaps or corners), it is recommended to wipe them regularly with a soft rag, soft brush, etc. and when necessary, combined with some auxiliary tools (such as thin sticks) to ensure no contaminants or bacteria accumulation in these areas.
- Do not use soaps, detergents, spray cleaners, etc. to clean the inside of your freezer as these may create odors or contamination.
- Clean the baskets with a soft cloth dampened with soapy water or diluted detergent. Dry with a soft cloth or dry naturally.
- Wipe the outer surface of the freezer with a soft cloth dampened with soapy water, detergent, etc., and then wipe dry.
- Do not use hard brushes, clean steel balls, wire brushes, abrasives (such as toothpastes), organic solvents (such as alcohol, acetone, banana oil, etc.), boiling water, acid or alkaline items, which may damage the freezer surface and interior. Boiling water and organic solvents such as benzene may deform or damage plastic parts.
- Do not rinse directly with water or other liquids during cleaning to avoid short circuits or affect electrical insulation after immersion.



⚠ Please unplug the freezer for defrost and cleaning.

3.2 Defrost

- Freezer shall be manually defrosted.
Unplug the freezer and open the freezer door, remove foods and shelving basket before defrosting; Open the outflow hole and drainage hole (and place water container at the outflow hole); indoor frost will naturally melt, wipe the defrost water with a dry, soft cloth. When the frost softens, an ice scraper might be used to the accelerate de-icing process.
- Please remove the food and put in a cool place when defrosting before removing accessories.

Other mechanical devices or other means shall not be used to accelerate except those recommended by the manufacturer. Do not damage the refrigerant circuit.

3.3 Stop using

- Power failure: Foods can be preserved for a couple of hours even in summer in case of power failure; it is recommended to reduce the frequency of opening door and do not put fresh foods into the freezer.
- Long-time nonuse: Please unplug the freezer left unused for a long time for cleaning. Keep the door open to avoid the bad odor.
- Moving: Do not turn upside or vibrate the freezer, the carrying angle can not be greater than 45° . Do not hold the door and hinge when moving this unit.

⚠ Continuous operation is recommended when the freezer is started. Please do not stop the freezer under normal circumstances so as not to affect the freezer's service life.

4 Trouble shooting

The following simple issues can be handled by the user. Please call the after-sale service department if the issues are not settled.

Not work	Whether the freezer is plugged and connected to power; Low voltage; Whether temperature control knob is in the work area; Failure power or tripping circuit.
Odor	Odorous foods should closely wrapped; Whether foods are rotten; Whether the interior shall be cleaned.
Long-term operation of compressor	It is normal that freezer operates for longer time in summer when the ambient temperature is higher; Do not put too much food in the freezer at one time; Do not put foods until they are cooled; Frequent opening of freezer door; Thick frost layer (defrost is needed).
Light doesn't work (only if fitted)	Whether the freezer is connected to power, whether the light is damaged.
Doors cannot be properly closed	The freezer door is stuck by food packages; Too much food; Unbalanced freezer.
Loud noises	Whether the floor is flat, whether the placement of freezer is stable; Whether the freezer accessories are properly placed.
Transient difficulty in door opening	After refrigeration, there will be pressure difference between the inside and outside of the freezer to result in transient difficulty in door opening. This is a normal physical phenomenon.
Over heat on sidewall	The freezer enclosure may emit heat during operation specially in summer, this is caused by the radiation of the condenser, and it is a normal phenomenon.
Surface condensation	Condensation: condensation phenomenon will be detected on the exterior surface and door seals of the freezer when the ambient humidity is large, this is a normal phenomenon, and the condensation can be wiped away with a dry towel.
Airflow sound Buzz Clatter	Refrigerants circulating in the refrigerant lines will produce eruption of sound and grunts which is normal does not affect the cooling effect. Buzz will be generated by running compressor specially when starting up or shutting down. The solenoid valve or electric switch valve will clatter which is a normal phenomenon and does not affect the operation.

Table 1 Climate classes

Class	Symbol	Ambient temperature range °C
Extended temperate	SN	+ 10 to + 32
Temperate	N	+ 16 to + 32
Subtropical	ST	+ 16 to + 38
Tropical	T	+ 16 to + 43

Extended temperate: 'this refrigerating appliance is intended to be used at ambient temperatures ranging from 10 °C to 32 °C';

temperate: 'this refrigerating appliance is intended to be used at ambient temperatures ranging from 16 °C to 32 °C';

Subtropical: 'this refrigerating appliance is intended to be used at ambient temperatures ranging from 16 °C to 38 °C';

Tropical: 'this refrigerating appliance is intended to be used at ambient temperatures ranging from 16 °C to 43 °C';

Special for new European standard

The ordered parts in the following table can be acquired from customer services.

Ordered Parted	Provided By	Minimum Time Required For provision.
Thermostats	Professional maintenance personnel	At least 7 years after the last model is launched on the market
Temperature Sensor	Professional maintenance personnel	At least 7 years after the last model is launched on the market
Printed Circuit board	Professional maintenance personnel	At least 7 years after the last model is launched on the market
Light Source	Professional repairers and final users	At least 7 years after the last model is launched on the market
Door Handles	Professional repairers and final users	At least 7 years after the last model is launched on the market
Door Hinges	Professional repairers and final users	At least 7 years after the last model is launched on the market
Trays	Professional repairers and final users	At least 7 years after the last model is launched on the market
Baskets	Professional repairers and final users	At least 7 years after the last model is launched on the market
Door gaskets	Professional repairers and final users	At least 10 years after the last model is launched on the market

Product Data Sheet concerning (EU) 2019/2016

The product data sheet for your appliance can be found online if you wish to download a copy.

Go to <https://eprel.ec.europa.eu> and enter the model identifier for your appliance to download the data sheet.

Alternatively you can download from <https://www.montpellier-appliances.com> by going to the relevant product page.

The model identifier for your appliance can be found on the rating plate at the rear/side of the appliance.

Here For You

After-sales assistance

If you continue to experience problems with your appliance, please call the Montpellier customer service helpline on: **01759 487839**

D`YUgY \ Uj Y` U`` nci f` dfcXi Wñ XYHU]`g` Uj U]`UV`Yž`]bWi X]b[` h Y` a cXY` bi a VYfž gYf]U` bi a VYfž cf][]bU` gU`Yg`]bj c]W` fWYUf` m` gl` ck]b[` a cXY` bi a VYfžXUH` cZ di fW Ugy` UbX` nci f` fYHU]`Yf]g` XYHU]`g` VYZ`fYfY[]ghYf]b[`UZU` `H`

The service call cannot progress without this information.

Your 2 year Manufacturer's guarantee

THIS DOES NOT AFFECT YOUR STATUTORY RIGHTS.

Your new Montpellier appliance carries a free guarantee which protects you against the cost of repairs during the first 24 months from date of purchase provided that:

Any claim is accompanied by evidence of the model reference, model serial number and proof of purchase, such as a Sales Receipt, showing that the appliance was purchased within the 24 months prior to the date of claim.

What is not covered under the Guarantee

- Any appliance not correctly installed and operated in accordance with the manufacturer's instructions
- Any appliance that is used for anything other than domestic purposes.
Any defect caused by accident, misuse, unauthorised modification or inexperienced repair.
- Cost of Call-out where a fault cannot be found with the appliance.
Cost of Call-out for work covering routine maintenance, such as, but not exclusively, cleaning of filters or defrosting.
- Cost of Call-out for work required to correct the alignment of doors following door reversal procedures carried out by you.
Use of the appliance by anyone other than the Householder.
Use in any commercial environment.
- Consumable items, such as, but not exclusively, fuses in plugs, bulbs and breakable items which require routine replacement.
Repair costs incurred that have not been authorised by Montpellier service and/or carried out by a non-approved Montpellier engineer.
- Montpellier Appliances do not accept claims for consequential loss, rusting, corroding, delivery damage or scratches.

YOUR GUARANTEE IS VALID ONLY IN THE UK & REPUBLIC OF IRELAND

To register your appliance simply complete the card in your appliance pack and return it with a stamp affixed. Alternatively you can register online at www.montpellier-appliances.com/support

SERVICE HELP-LINE

Should your appliance develop a fault, please call the Montpellier customer service helpline on:

01759 487839

D`YUgYfYa Ya VYf]c\ Uj YU` nci f` dfcXi WñXYHU]`g` Uj U]`UV`Yž`]bWi X]b[` h Y` a cXY` bi a VYfž gYf]U` bi a VYfžXUH` cZ di fW Ugy` UbX` nci f` fYHU]`Yf]g` XYHU]`g` VYZ`fYfY[]ghYf]b[`UZU` `H`

Montpellier Domestic Appliances Ltd.
Unit 1, Tewkesbury Retail Park, Northway Lane,
Tewkesbury, Gloucestershire GL20 8JU

www.montpellier-appliances.com



The symbol on the product or on its packaging indicates that this product may not be treated as household waste. Instead it shall be handed over to the applicable collection point for the recycling of electrical and electronic equipment. By ensuring this product is disposed of correctly, you will help prevent potential negative consequences for the environment and human health, which could otherwise be caused by inappropriate waste handling of this product. For more detailed information about recycling of this product, please contact your local city office, your household waste disposal service or the shop where you purchased the product.